



Quick Reference Guide

Using the AGB3303 as a Replacement for the NGA-589

The AGB3303 InGaP HBT Gain Block from ANADIGICS is a wideband device with high linearity, low noise and low distortion that can be used as a replacement for the NGA-589 device from Sirenza Microdevices. Both offered in convenient SOT-89 surface mount packages, the two devices have comparable performance metrics and application circuits:

NGA-589 ELECTRICAL CHARACTERISTICS

PARAMETER	FREQUENCY	VALUE
Gain	850 MHz	20.0 dB
	1950 MHz	19.2 dB
Output IP3	850 MHz	+39 dBm
	1950 MHz	+34 dBm
Output P1dB	850 MHz	+19.0 dB
	1950 MHz	+18.8 dB
Noise Figure	850 MHz	3.5 dB
Device Current		80 mA

Test Conditions: $V_S = +8V$, $R_B = 39\Omega$ for 80mA current, Ambient Temperature = +25°C, 50Ω system.

AGB3303 ELECTRICAL CHARACTERISTICS

PARAMETER	FREQUENCY	VALUE
Gain	850 MHz	20.5 dB
	1950 MHz	18.7 dB
Output IP3	850 MHz	+39 dBm
	1950 MHz	+39 dBm
Output P1dB	850 MHz	+20 dB
	1950 MHz	+20 dB
Noise Figure	850 MHz	4.5 dB
Device Current		80 mA

Test Conditions: $V_S = +8V$, $R_B = 38\Omega$ for 80mA current, Ambient Temperature = +25°C, 50Ω system.

NGA-589 APPLICATION CIRCUIT

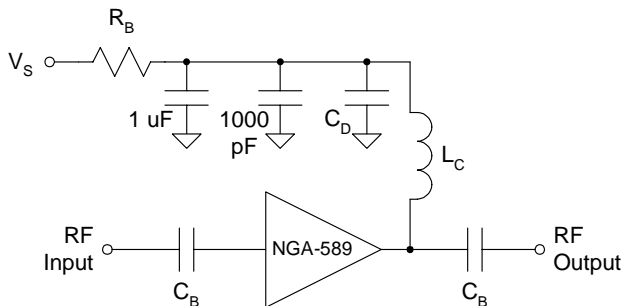

AGB3303 APPLICATION CIRCUIT

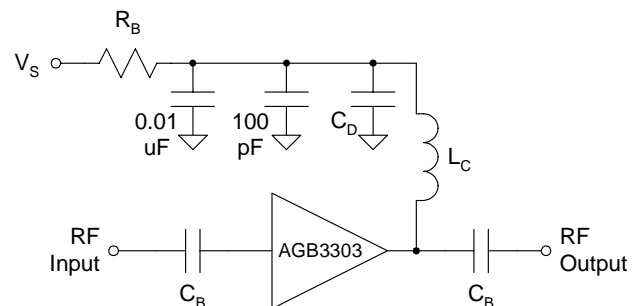

NGA-589 COMPONENT	FREQUENCY	
	850 MHz	1950 MHz
C_B	100 pF	68 pF
C_D	68 pF	22 pF
L_C	33 nH	22 nH

AGB3303 COMPONENT	FREQUENCY	
	850 MHz	1950 MHz
C_B	0.01 uF	0.01 uF
C_D	10 pF	10 pF
L_C	100 nH	100 nH

Recommended Bias Resistor Values for 80mA Current on NGA-589				
V_S	+7.5 V	+8 V	+10 V	+12 V
R_B	33 Ω	39 Ω	62 Ω	91 Ω

Recommended Bias Resistor Values for 80mA Current on AGB3303				
V_S	+7.5 V	+8 V	+10 V	+12 V
R_B	32 Ω	38 Ω	63 Ω	88 Ω

The information contained herein is presented for reference only. Actual performance of the AGB3303 device is detailed in the product data sheet. NGA-589 device performance is extracted from Rev C of the product data sheet.