



## Application Note

Using the ACA0861D  
at +8 V and +5 V Supply Voltages  
Rev 0

Although the ACA0861D Line Amplifier IC is designed for optimum operation with a +12 VDC supply, it is possible to operate the part at reduced supply voltages, with some performance reduction.

For such an operation, a slight change in external bias conditions has to be implemented, depending on the voltage level chosen.

**Table 1: Summary of Typical Single Part Performance <sup>(1)</sup>**

SUPPLY VOLTAGE	+12	+8	+5	V
Current	470	420	230	mA
Gain	12	11.5	11	dB
CTB				
128 ch flat +36 dBmV	-71	-68	-	dBc
128 ch flat +32 dBmV	-	-	-62	
CSO				
128 ch flat +36 dBmV	-73	-70	-	dBc
128 ch flat +32 dBmV	-	-	-62	
Xmod				
128 ch flat +36 dBmV	-67	-65	-	dBc
128 ch flat +32 dBmV	-	-	-57	

*(1) Two devices can be cascaded together for higher gain applications. See ACA0861 Data Sheet for details.*

**Table 2: Connections for Proper Bias**

SUPPLY VOLTAGE	(Normal Operation) 12 VOLTS	8 VOLTS	5 VOLTS
Pin 2	No Connection (Open)	3.9 K $\Omega$ to GND	2 K $\Omega$ to V <sub>DD</sub> (+5 V)
Pin 7	No Connection (Open)	5.1 K $\Omega$ to V <sub>DD</sub> (+8 V) 1.5 K $\Omega$ to GND	470 $\Omega$ to GND

# Using the ACA0861D at +8 V and +5 V Supply Voltages

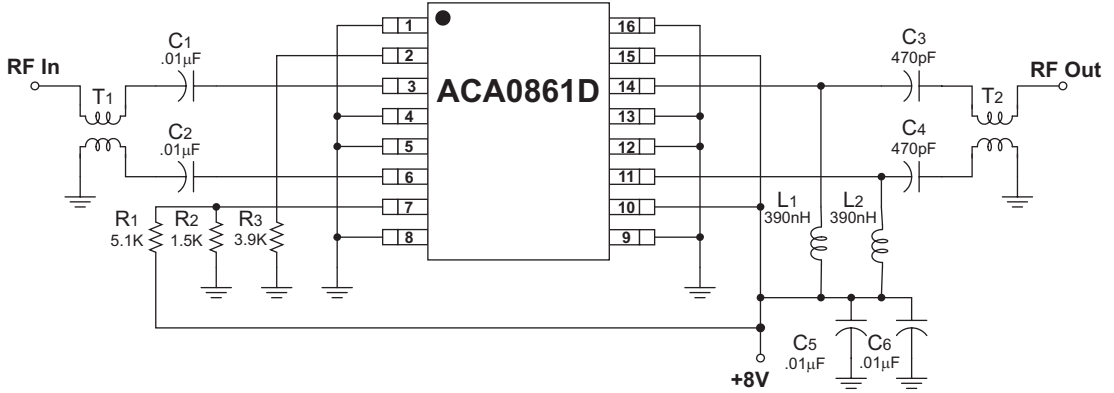
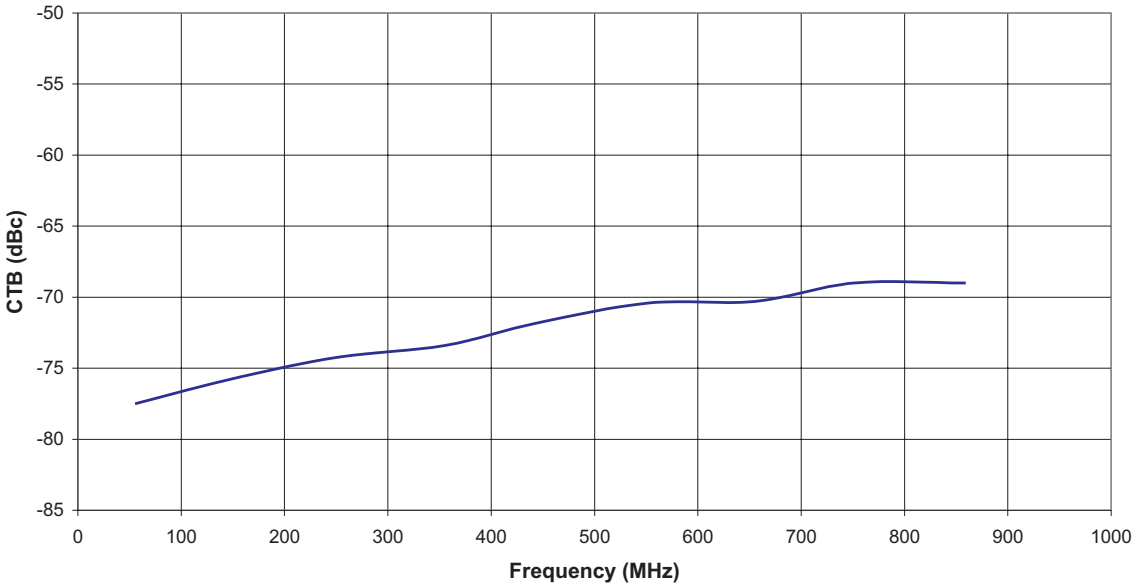
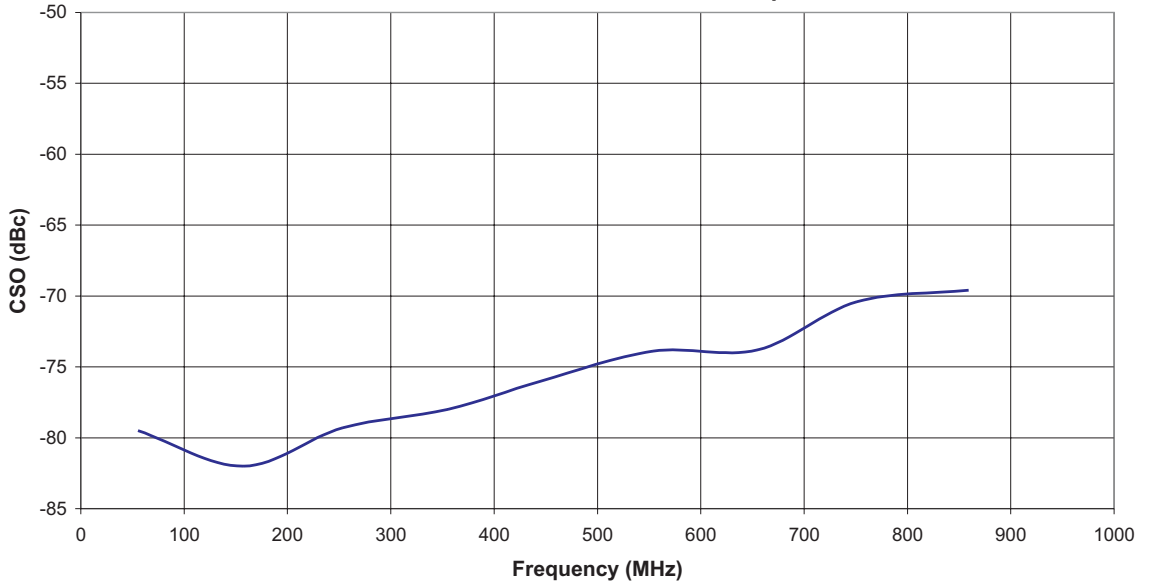

Figure 1: Test Circuit for +8 Volt V<sub>DD</sub>

Figure 2: CTB at +8 V, 420 mA  
128 Channels Flat, +36 dBmV Output



**Figure 3: CSO at +8 V, 420 mA**  
**128 Channels Flat, +36 dBmV Output**



**Figure 4: Xmod +8 V, 420 mA**  
**128 Channels Flat, +36 dBmV Output**

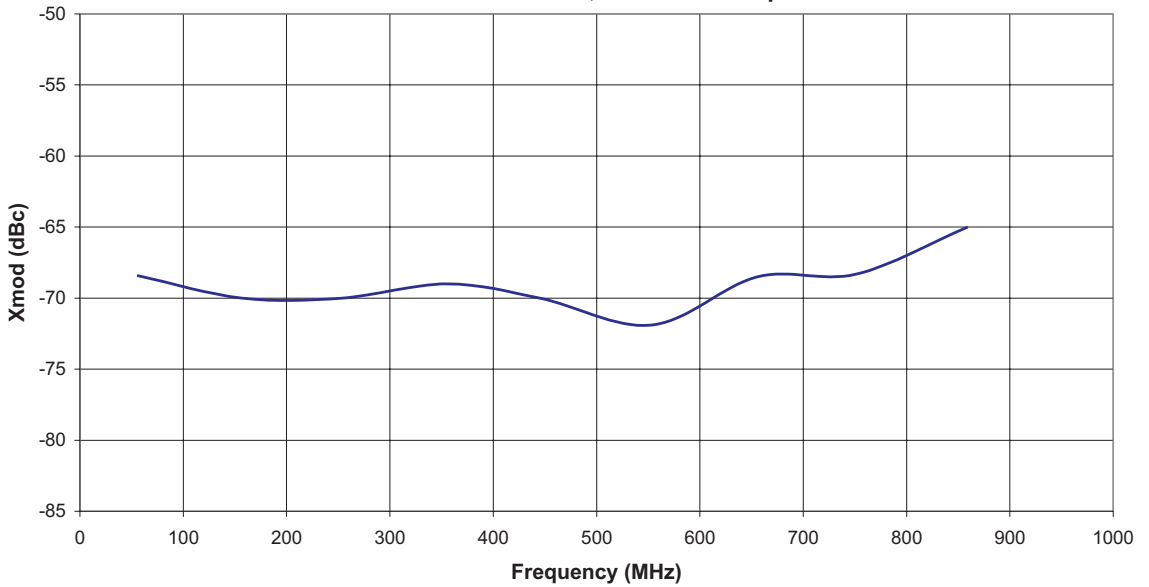

Figure 5: S11 at +8 V

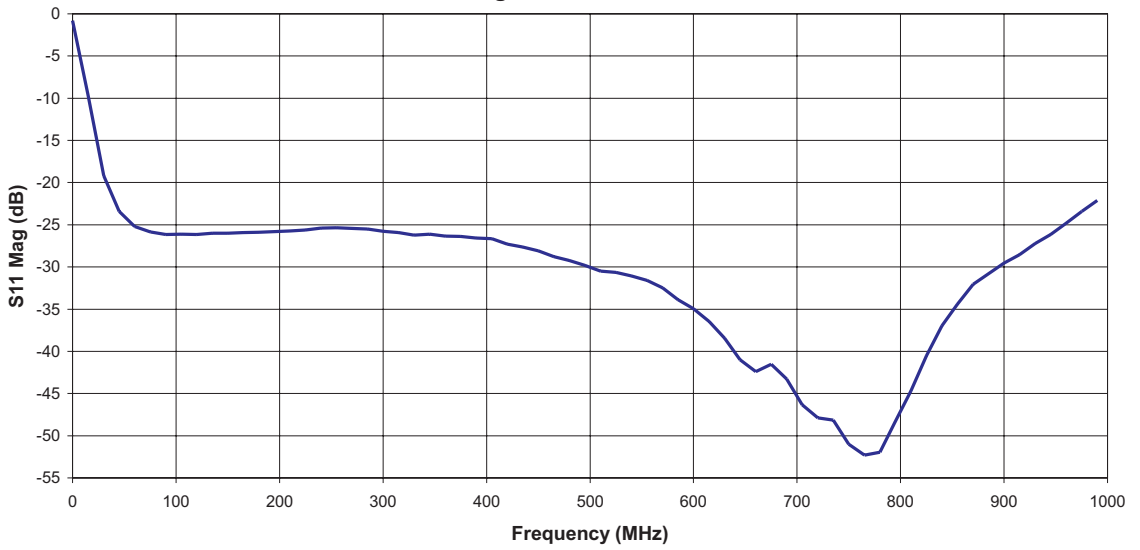

Figure 6: S21 at +8 V

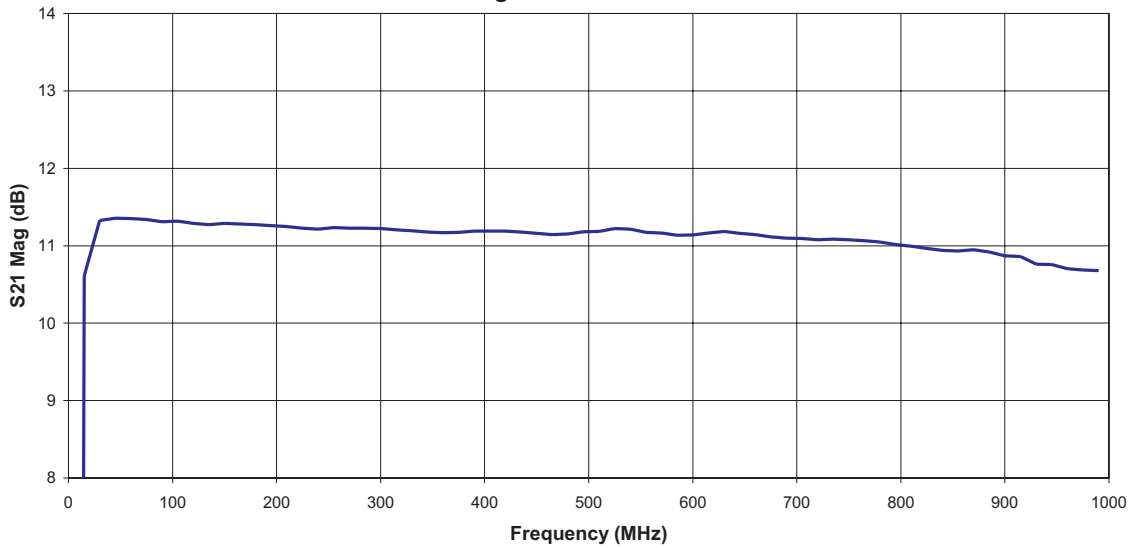

Figure 7: S12 at +8 V

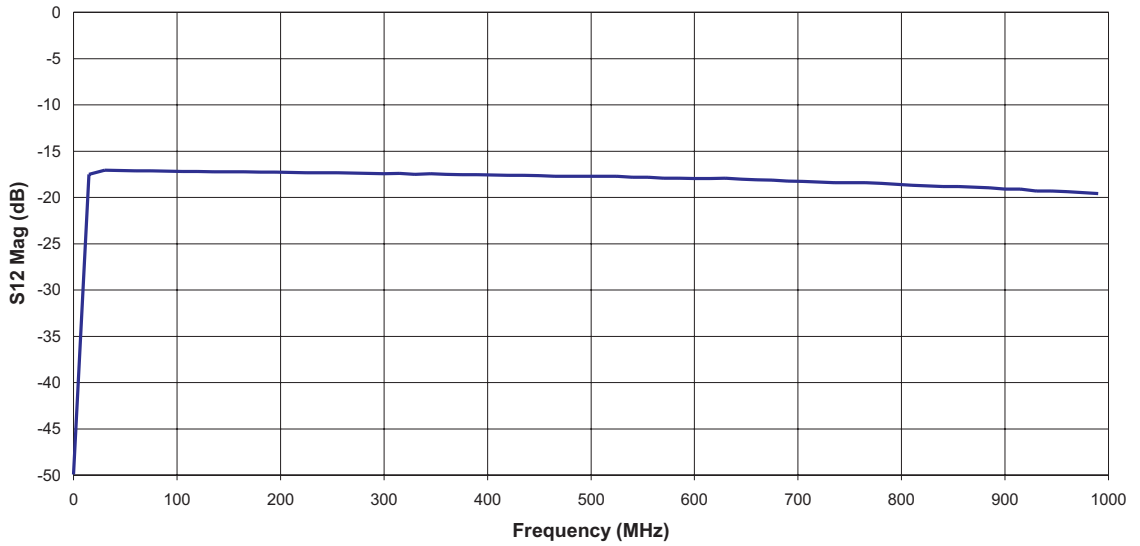
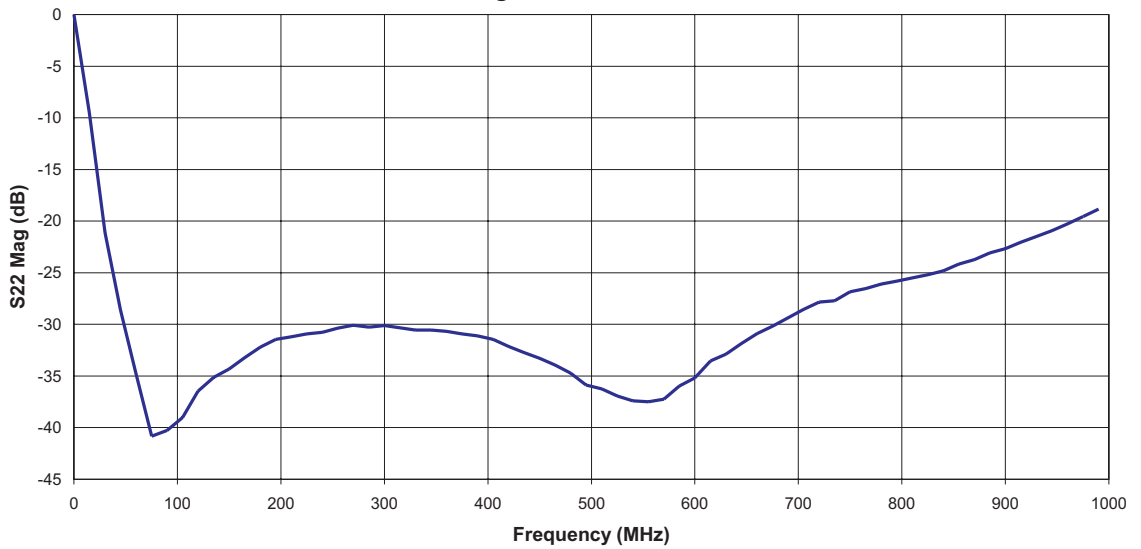

Figure 8: S22 at +8 V



## Using the ACA0861D at +8 V and +5 V Supply Voltages

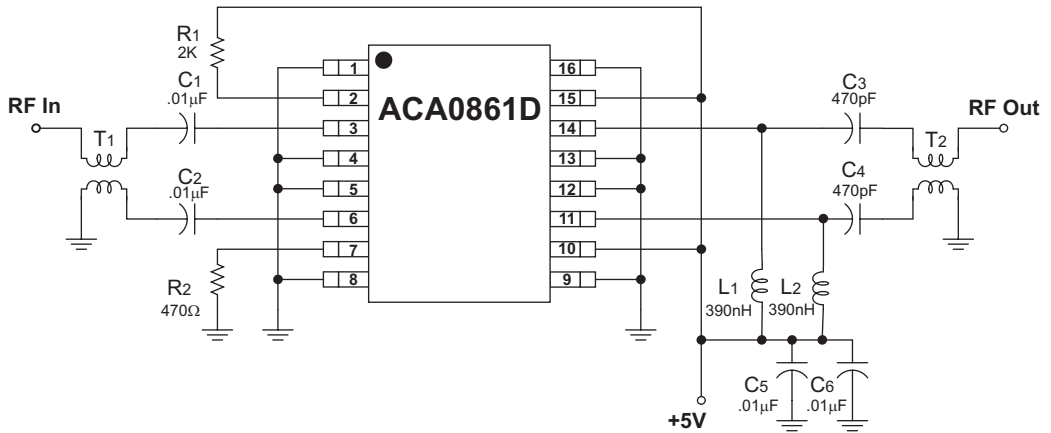
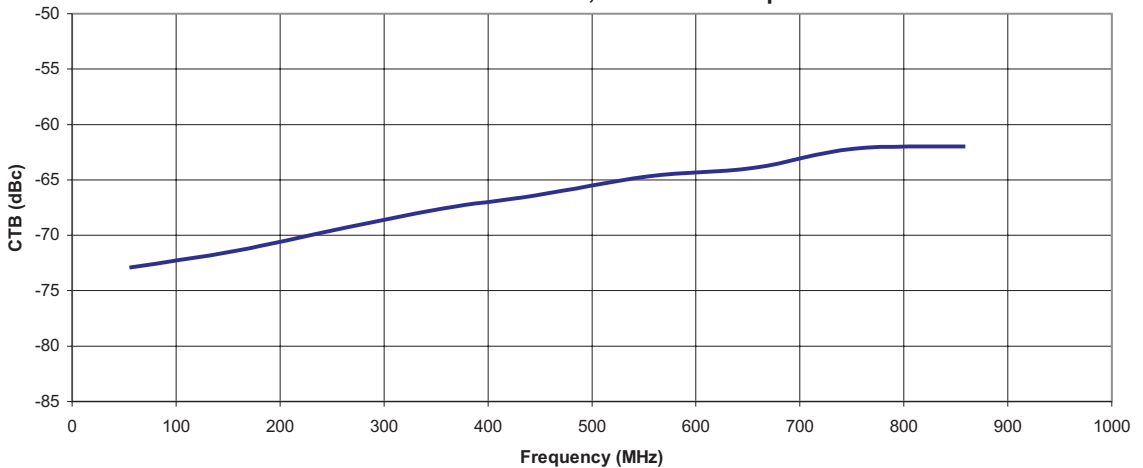
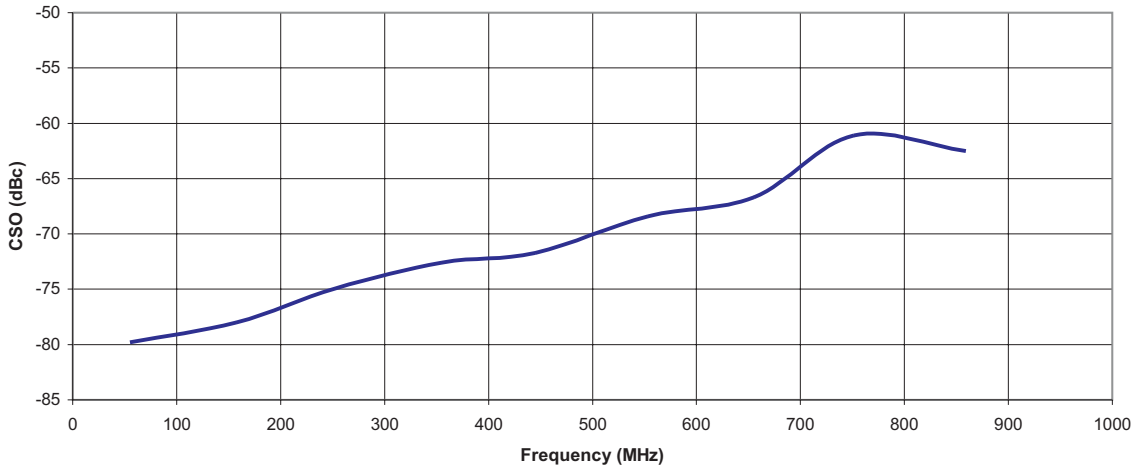

Figure 9: Test Circuit for +5 Volt V<sub>DD</sub>

Figure 10: CTB at +5 V, 230 mA  
128 Channels Flat, +32 dBmV Output



**Figure 11: CSO at +5 V, 230 mA**  
**128 Channels Flat, +32 dBmV Output**



**Figure 12: Xmod at +5 V, 230 mA**  
**128 Channels Flat, +32 dBmV Output**

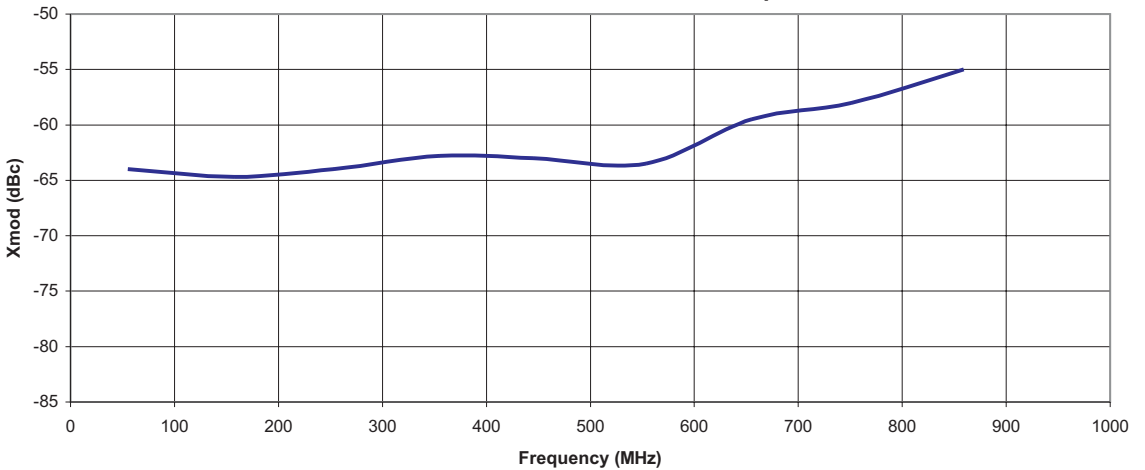

Figure 13: S11 at +5 V

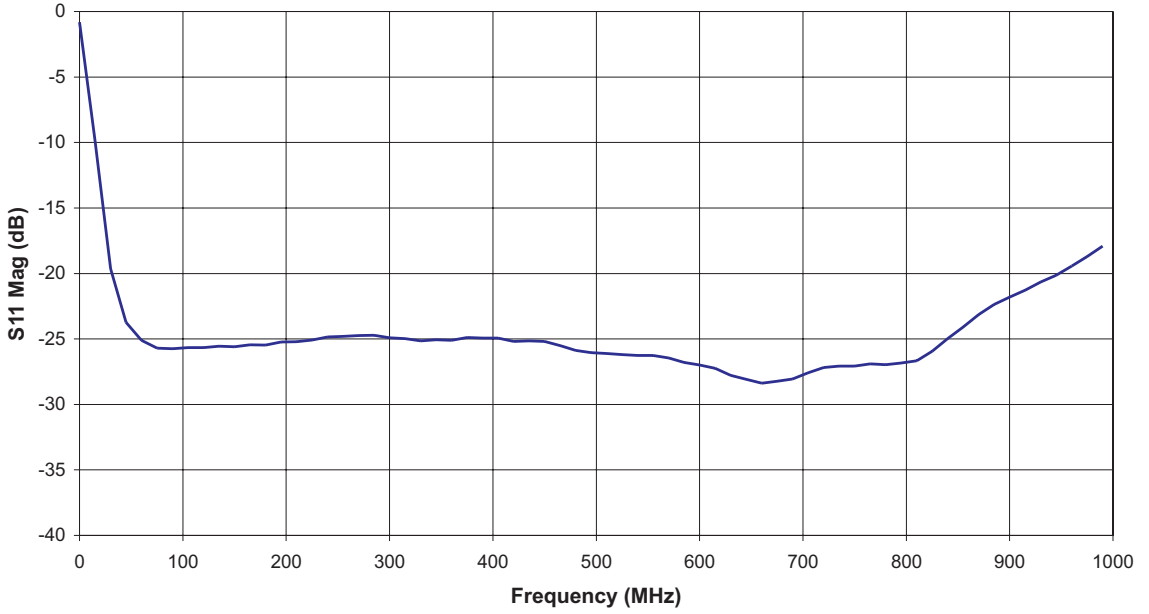

Figure 14: S21 at +5 V

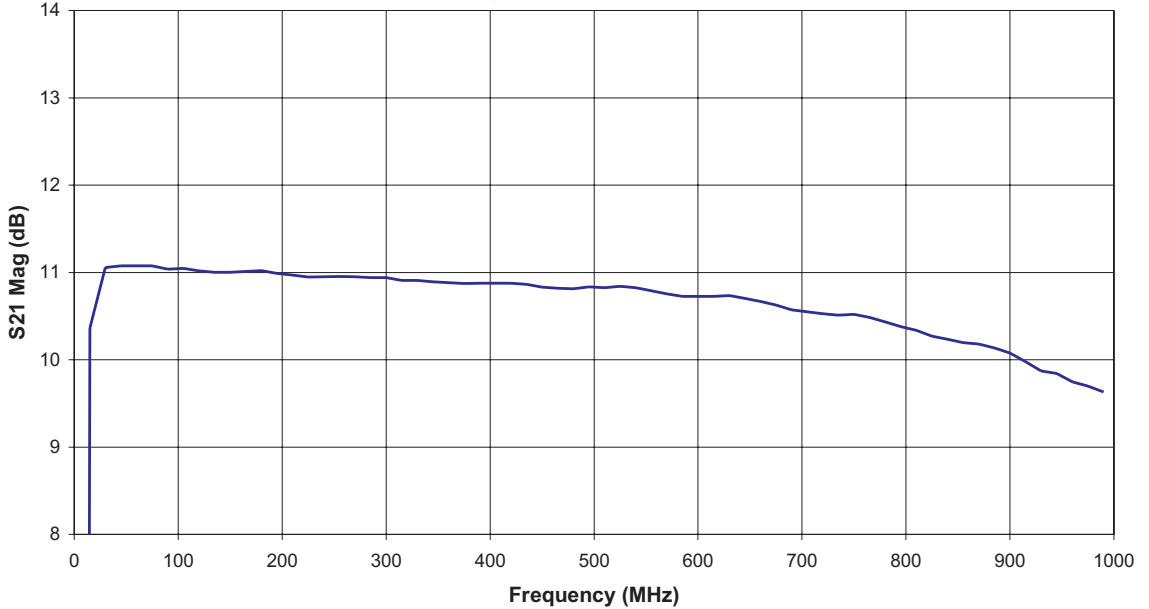

Figure 15: S12 at +5 V

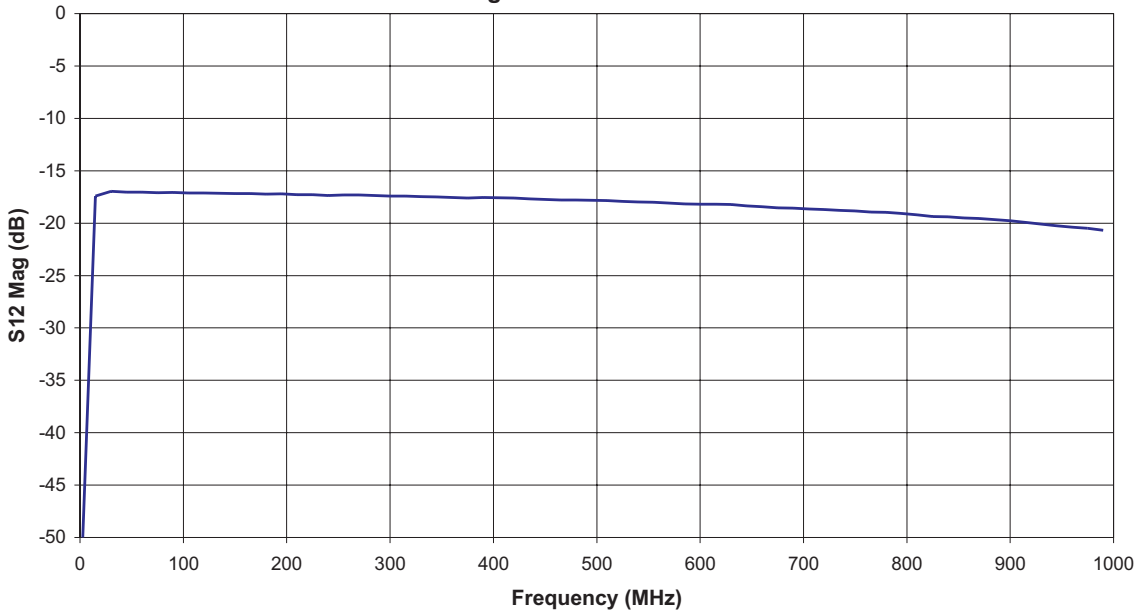
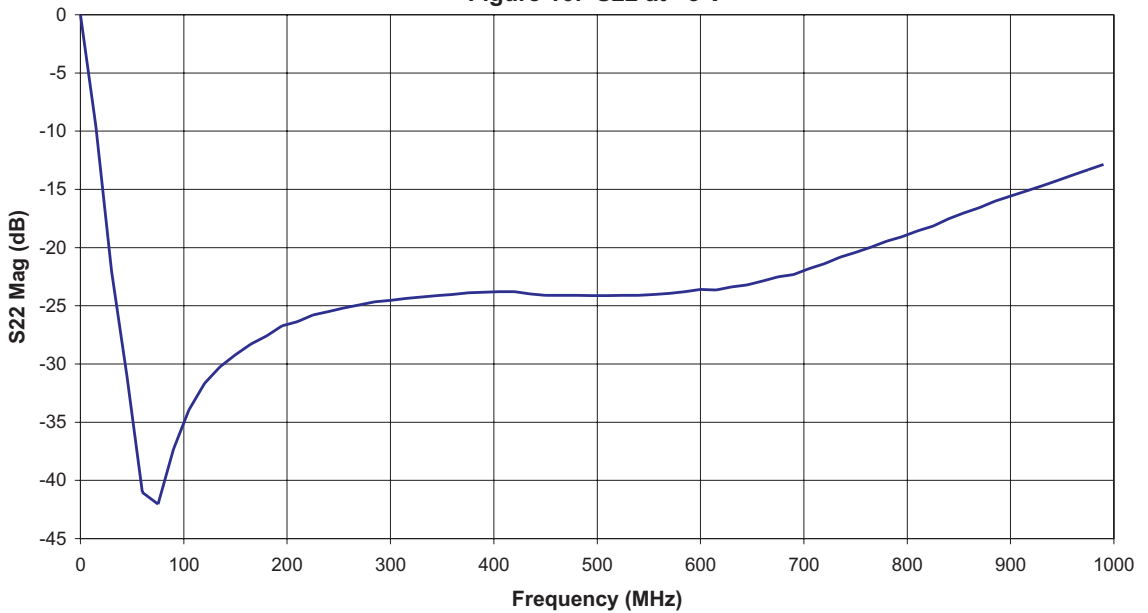

Figure 16: S22 at +5 V



NOTES

NOTES



**ANADIGICS, Inc.**

141 Mount Bethel Road  
Warren, New Jersey 07059, U.S.A.  
Tel: +1 (908) 668-5000  
Fax: +1 (908) 668-5132

URL: <http://www.anadigics.com>  
E-mail: [Mktg@anadigics.com](mailto:Mktg@anadigics.com)

**IMPORTANT NOTICE**

ANADIGICS, Inc. reserves the right to make changes to its products or to discontinue any product at any time without notice. The product specifications contained in Advanced Product Information sheets and Preliminary Data Sheets are subject to change prior to a product's formal introduction. Information in Data Sheets have been carefully checked and are assumed to be reliable; however, ANADIGICS assumes no responsibilities for inaccuracies. ANADIGICS strongly urges customers to verify that the information they are using is current before placing orders.

**WARNING**

ANADIGICS products are not intended for use in life support appliances, devices or systems. Use of an ANADIGICS product in any such application without written consent is prohibited.