

OBJECTIVE

The objective of this application note is to provide ANADIGICS' customers' general guidelines for PCB second level interconnect design when assembling with ANADIGICS' module products.

INTRODUCTION

Reflow soldering of surface mount assemblies provides mechanical, thermal and electrical connections between the component leads or terminations, and the customer surface mount land pads. Solder paste can be applied to the surface mount lands by various methods, the most common being screen-printing and stencil printing [1].

ANADIGICS' modules are categorized as surface mount components (SMCs). Unlike through-hole components, SMCs rely entirely upon the solder interface for mechanical strength [2]. The solder joint properties, and therefore the solder joint design, are of critical importance to the user of the SMC.

PCB BOARD DESIGN

Refer to the appendices for the recommended PCB metal design, soldermask design, and stencil print patterns when assembling with ANADIGICS' modules.

It is important to note that the PCB metal design is dependent upon several factors: the electrical and thermal performance requirements of the product and the PCB-to-device interconnect pattern. The PCB metal design recommendations in the appendices primarily deal with the PCB-to-device interconnection. Specific board-level electrical and thermal performance requirements will be dictated by the physical geometry of the specific application and are the responsibility of the end product manufacturer.

SOLDER PASTE APPLICATION METHODS

Solder paste can be applied using screen printing, stencil printing or dispensing, with screen/stencil printing being the most common high volume solder application method. Using these methods, the solder paste is applied on the top surface of the screen or stencil with the print squeegee at one end of the stencil. During the printing process, the squeegee

presses down on the stencil to the extent that the bottom of the stencil touches the surface of the board. The solder paste is then printed on the land through the opening in the stencil when the squeegee traverses the entire length of the image area on the metal mask.

Although the print processes for stencil and screen-printing are similar, the differences lie in the construction of the mask. A screen utilizes an emulsion laminated over a wire mesh. The wire mesh provides mechanical support while the emulsion defines the solder print pattern. Therefore an opening in a screen will contain wire mesh around which the solder paste must flow to reach the PCB surface. A stencil is fabricated from a thin sheet of metal in which the solder print patterns are defined by etched or lasered openings in the metal sheet. Therefore an opening in the stencil will provide an unobstructed path for the solder paste flow. Stencils however have the disadvantage of being dependent on over-etching, which can occur during its fabrication. The choice of stencil or screen depends on the application.

Solder paste can also be dispensed by pressure/time systems, auger valves or positive displacement valves. Using these methods solder paste is dispensed in a serial manner, thus the process rate is much slower than that of stencil or screen-printing. Dispensing is often used in small volume engineering, high product mix or rework applications due to its process flexibility. Additionally, dispensing may have special applications for products that require different print thicknesses on a single board.

PRINT THICKNESS

Both print thickness and print pattern will determine the volume of solder in the resulting joints. Once the proper print area is defined, the thickness can be varied to obtain the proper volume. Solder paste that is too thick will result in excessive solder in the joints. This may cause solder balls and/or solder bridging between components or pads. Solder paste that is too thin may result in insufficient solder fillets and/or voids in the solder. This may degrade the mechanical, thermal and electrical properties of the solder. To the first order, the thickness of the paste print is

Soldering Guidelines for Module PCB Mounting

stencil (or the emulsion thickness and mesh diameter of a screen). Varying the print process parameters and the percent metal content of the solder paste can modify this baseline thickness.

REFLOW SPECIFICATIONS

The reflow profile is a critical part of the PCB assembly process. A proper reflow profile must provide adequate time for flux volatilization, proper peak temperature, time above liquidous, ramp up and cool down rates. The profile used has a direct bearing on manufacturing yield, solder joint integrity, and the reliability of the assembly [3]. A typical reflow profile is made up of four distinct zones: the preheat zone, the soak zone/ flux activation zone, the reflow zone, and the cooling zone [4].

Preheat Zone

Typically the heating rate in the preheat zone should be 2 °C to 4 °C/second and the peak temperature in this zone should be 100-125 °C. If the temperature ramp is too fast, the solder paste may splatter and cause formation of solder balls. Also, to avoid thermal shock to sensitive components such as ceramic chip resistors, the maximum heating rate should be controlled.

Soak Zone

The soak zone is intended to allow the board and components to reach a uniform temperature, minimizing thermal gradients. The soak zone also acts to activate the flux within the solder paste. The ramp rate in this zone is very low and the temperature is raised near the melting point of solder (183 °C for standard 63Sn27Pb solder). The consequences of being at too high a temperature in the soak zone are solder balls due to insufficient fluxing (when the ramp rate is too fast) and solder splatter due to excessive oxidation of paste (when the ramp rate is too slow). Typical soak times are usually around the range of 130 –170 °C for 60 to 90 seconds.

Reflow Zone

In this zone the temperature is kept above the melting point of the solder for 60 to 150 seconds (as shown in tables 1 & 2. The peak temperature in this zone should be high enough for adequate flux action and to obtain good wetting. For standard 63Sn37Pb solders, a peak temperature range of 215 – 220 °C is generally considered acceptable. For Pb-Free solders the peak temperature is usually between 250 - 260 °C.

The temperature, however, should not be so high as to cause component damage, board damage, discoloration or charring of the board. Extended duration above the solder melting point will damage temperature sensitive components and potentially create excessive intermetallic growth between the solder and the I/O pad metallization which makes the solder joint brittle and reduces solder joint fatigue resistance. Additionally high temperatures can promote oxide growth, depending upon the furnace atmosphere, which can degrade solder wetting.

Cooling Zone

The cooling rate of the solder joint after reflow is also important. For a given solder system, the cooling rate is directly associated with the resulting microstructure which in turn, affects the mechanical behavior of solder joints. The faster the cooling rate, the smaller the grain size of the solder will be, and hence the higher the fatigue resistance of the solder joint. Conversely rapid cooling will result in residual stresses between TCE mismatched components. Therefore the cooling rate needs to be optimized.

The profile of choice can affect any of the following areas, to a different degree, by one of more of the profile zones [3].

- Temperature distribution across the assembly
- Plastic IC package cracking
- Solder balling
- Solder beading
- Wetting ability
- Residue cleanability
- Residue appearance and characteristics
- Solder joint voids
- Metallurgical reactions between solder and substrate surface
- Board flatness
- Microstructure of solder joints
- Residual stress level of the assembly

REFLOW PROFILES

Table 1 provides a breakdown of the reflow conditions provided by the JEDEC standard J-STD-020C [5] for lead-based solders.

Table 2 provides a breakdown of the reflow conditions provided by the JEDEC standard J-STD-020C [5] for leadfree solders. While, this standard specifies a peak reflow temperature of 260 °C, the actual peak temperature subjected to the parts during qualification will be dependent on the particular products' high temperature tolerating capabilities.

Table 1: Standard Reflow Profile Breakdown

	JEDEC specifications
Avg. Ramp-up (T_L to T_P) ^{(1),(2)}	3 °C/second max
Dwell Time (125 ± 25 °C)	60 seconds to 120 seconds
Time above T_L ⁽¹⁾	60 seconds to 150 seconds
Time within 5 °C of peak	10 seconds to 30 seconds max
Peak Temperature (JEDEC)	240 -5/+0 °C
Average Ramp-down	6 °C/second max

Notes:

- (1) T_L is the solder Eutectic temperature.
- (2) T_P is the peak temperature.

Table 2: Standard Reflow Profile Breakdown

	JEDEC specifications
Avg. Ramp-up (T_L to T_P) ^{(1),(2)}	3 °C/second max
Dwell Time (175 ± 25 °C)	60-120 seconds
Ramp-up 200 °C to 217 °C	3 °C/second max
Time above 217 °C	60 seconds to 150 seconds
Time within 5 °C of Peak	20 seconds to 40 seconds
Peak Temperature ⁽³⁾	260 -5/+0 °C
Average Ramp-down	6 °C/second max

Notes:

- (1) T_L is the solder Eutectic temperature.
- (2) T_P is the peak temperature.
- (3) Actual peak temperature will be product dependent.

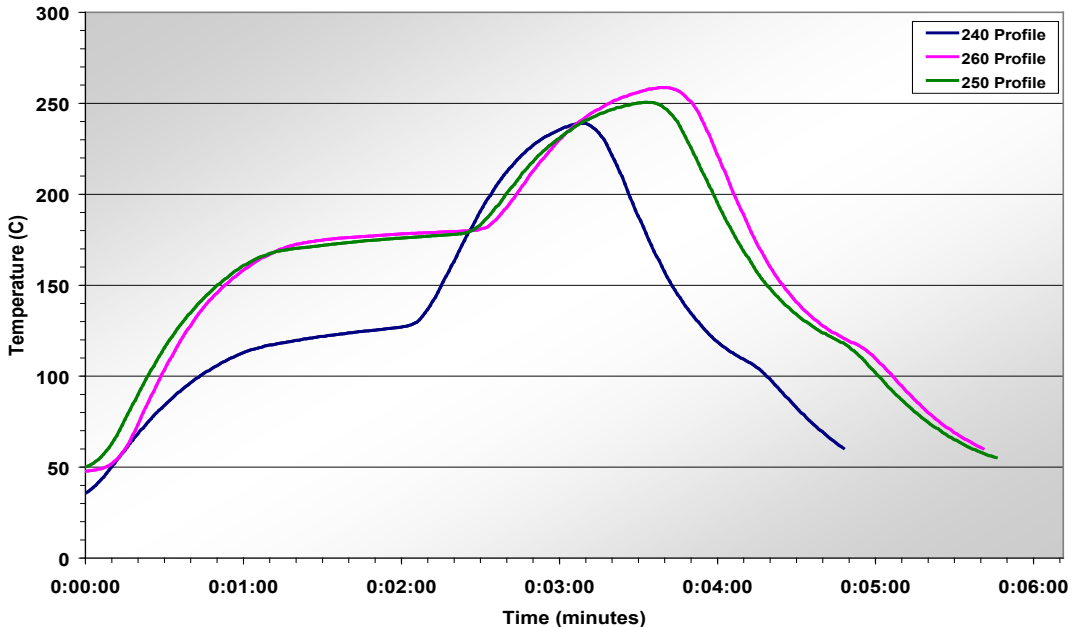

Figure 1: Comparison of High Temperature Reflow Profiles

Soldering Guidelines for Module PCB Mounting

REWORK GUIDELINE

The most common method of repairing surface mount devices is by using hot air devices. During this rework process care should be taken to prevent thermal damage to adjacent component or substrates. The following guidelines should be used to prevent thermal damage and to produce an acceptable solder joint after repair/rework [1]:

- Characterize the rework process carefully so as not to overheat and damage the device.
- Keep the number of times a part is removed and replaced to a maximum of two.
- Preheat the substrate for about 30 minutes to about 95 °C.
- Use an appropriate attachment to direct the flow of hot air to the component to be removed or replaced.
- Minimize the heat time to reduce the device exposure to high temperatures.

Component Removal, Rework and Remount [8]

If a component is to be removed from the board, it is recommended that localized heating be used and the maximum body temperatures of any surface mount component on the board not exceed 200°C. Furthermore it is critical that the maximum body temperature never exceed 260 °C. This method will minimize moisture related component damage. If it is anticipated that any component temperature will exceed 200°C, the board must be baked prior to rework and/or component removal. This bakeout acts to desorb destructive moisture from the components prior to rework. A default board assembly bake-out temperature of 125°C for 24 hours shall be used, except in cases where components and/or board materials cannot withstand this condition. Component temperatures shall be measured at the top center of the package body. Any SMD package that has not exceeded its floor life can be exposed to a maximum body temperature as high as its maximum reflow temperature as defined by J-STD-020.

Removal for Failure Analysis [8]

Not following the requirements detailed section titled **Component Removal, Rework and Remount** may cause moisture/reflow damage that could hinder or completely prevent the determination of the original failure mechanism.

Removal and reinstallation or replacement of a component should be conducted following IPC-7711 or IPC-7721. If a component is to be removed

and reinstalled it may be necessary to first bake the printed wiring assembly to eliminate moisture from the component. When identifying a bake cycle the maximum exposure temperature and maximum rate of temperature change of components and materials on the subject printed wiring assembly must be considered and an appropriate time temperature profile (see IPC-7711) used. An SMD package shall not exceed its MSL ratings per J-STD-020 at any time during replacement. Localized replacement reflow heating is recommended, so that the entire board is not re-subjected to reflow temperature profiles. It is important to note that temperatures on neighboring SMD packages above the melting point of the solder being used may cause some solder joints to partially reflow, which may result in a potential solder joint reliability concern.

REFERENCES

- [1] Ray P. Prasad; Surface Mount Technology - Principles and Practice; Van Nostrand Reinhold – New York; 1989; Pages 311-328.
- [2] <http://www.tutorialsweb.com/smt/smt.htm>
- [3] Charles Harper; Electronic Packaging and Interconnect Handbook; “Solder Technologies for Electronic Packaging Assembly”; McGraw-Hill 2000; Pages 6.1-6.83.
- [4] <http://www.ecd.com/emfg/instruments/tech1.asp>
- [5] JEDEC Standard J-STD-020C. Moisture/Reflow Sensitivity Classification for non-hermetic Solid State Surface Mount Devices. July 2004.
- [6] ANADIGICS Application Note: Solder Reflow Report. Revision 1.
- [7] ANADIGICS Application Note: High Temperature Report. Rev. 2
- [8] JEDEC Standard J-STD-033B.1. Handling, Packing, Shipping and Use of Moisture/Reflow Sensitive Surface Mount Devices. January 2007

Soldering Guidelines for Module PCB Mounting

SPECIFICATION: P8002131
 SUBJECT: PCB DESIGN
 2nd LEVEL INTERCONNECT
 3mm X 3mm MODULE.

REV.	DESCRIPTION	CHKD./APPVD.	DATE	REV.	DESCRIPTION	CHKD./APPVD.	DATE
-	INITIAL RELEASE	M.A.W. M.L.A.	10-06-03	-	-	-	-

This document is proprietary information and may not be reproduced without the written consent of ANADIGICS, INC.

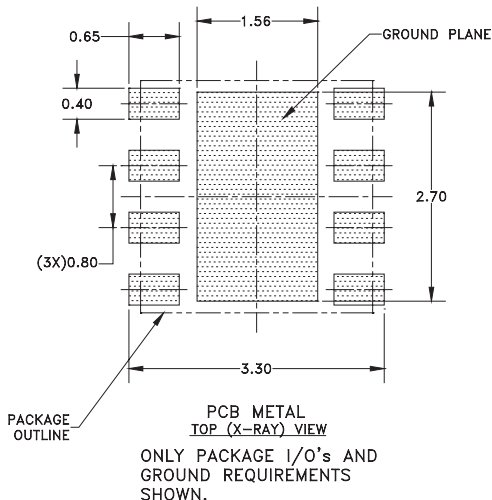

- NOTES:
- (1) OUTLINE DRAWING REFERENCE:
 * P8002087
 * P8002088
 - (2) UNLESS SPECIFIED DIMENSIONS ARE SYMMETRICAL ABOUT CENTER LINES SHOWN.
 - (3) DIMENSIONS IN MILLIMETERS.

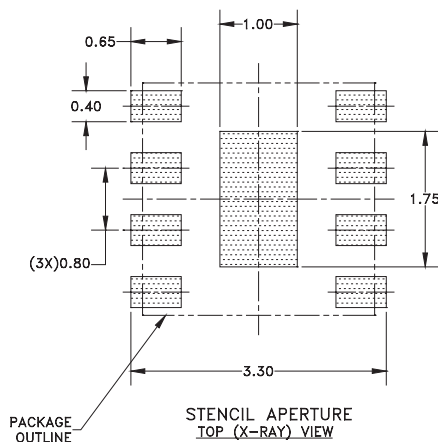
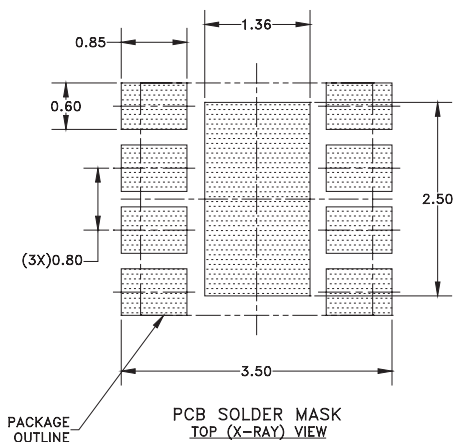

APPENDIX A: 3 mm x 3 mm Module Package Outlines

Soldering Guidelines for Module PCB Mounting

SPECIFICATION: P8002132
SUBJECT: PCB DESIGN

2nd LEVEL INTERCONNECT
4mm X 4mm MODULE.

REV.	DESCRIPTION	CHKD./APPD.	DATE	REV.	DESCRIPTION	CHKD./APPD.	DATE
-	INITIAL RELEASE	M.A.W. W.E.A.	10-06-03	A	CORRECTED PCB SOLDER MASK I/O DIMENSIONS.	M.A.W. W.E.A.	11-12-03
B	ADDED NEW OUTLINE DRAWING 98000-071	M.A.W. W.E.A.	11-29-07				

This document is proprietary information and may not be reproduced without the written consent of ANADIGICS, INC.

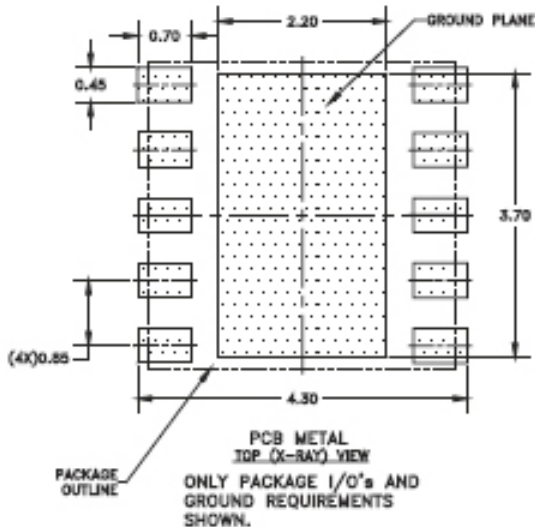

NOTES:

- (1) OUTLINE DRAWING REFERENCE:
 - * 98000-042
 - * 98000-045
 - * P8002079
 - * 98000-071
- (2) UNLESS SPECIFIED DIMENSIONS ARE SYMMETRICAL ABOUT CENTER LINES SHOWN.
- (3) DIMENSIONS IN MILLIMETERS.

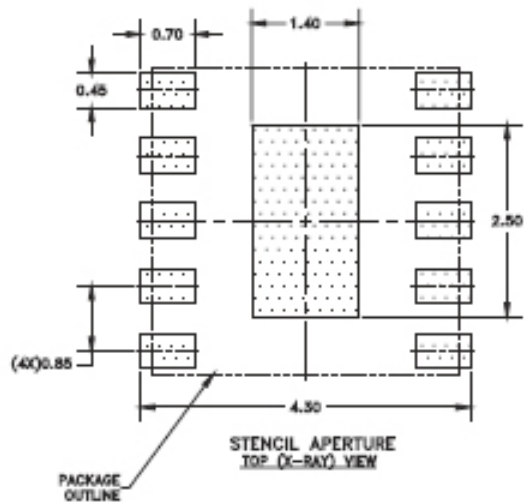
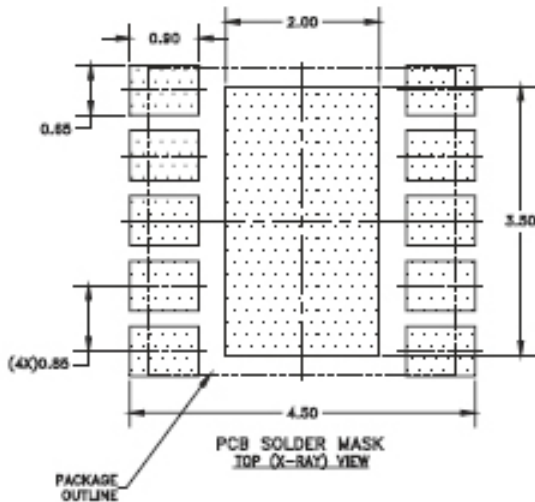

APPENDIX B: 4 mm x 4 mm Module Package Outlines

Soldering Guidelines for Module PCB Mounting

SPECIFICATION: 18002100
 SUBJECT: PCB DESIGN
 2nd LEVEL INTERCONNECT
 7mm X 10mm MODULE.

REV.	DESCRIPTION	CHKD./APPVD.	DATE	REV.	DESCRIPTION	CHKD./APPVD.	DATE
A	Resized Stencil Openings	M.A.W.	10/22/03	-	-	-	-

This document is proprietary information and may not be reproduced without the written consent of ANADIGICS, INC.

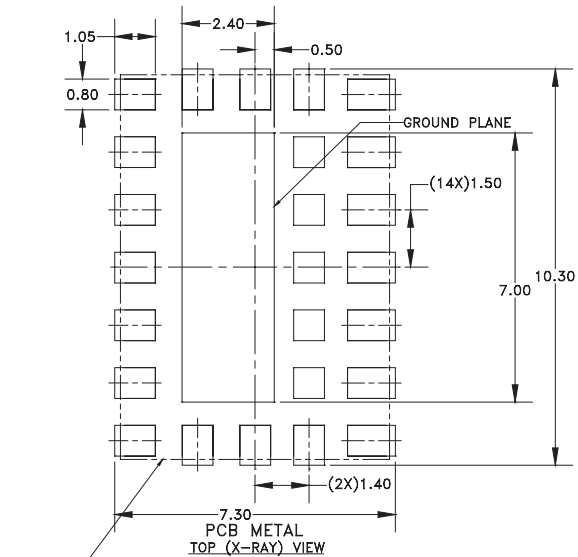

NOTES:

- (1) OUTLINE DRAWING REFERENCE: 98000-044
- (2) UNLESS SPECIFIED DIMENSIONS ARE SYMMETRICAL ABOUT CENTER LINES SHOWN.
- (3) DIMENSIONS IN MILLIMETERS.

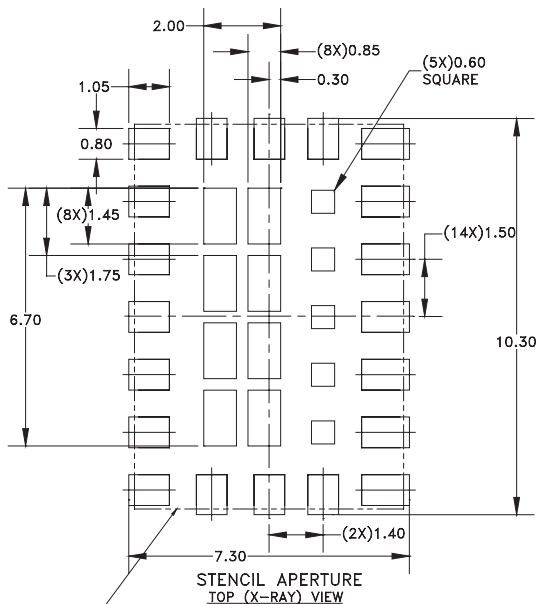
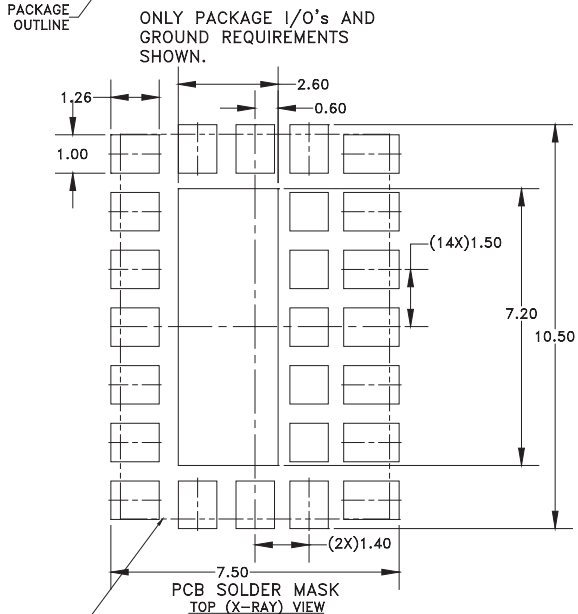

APPENDIX C: 7 mm x 10 mm Module Package Outlines

Soldering Guidelines for Module PCB Mounting

SPECIFICATION: P8002144
SUBJECT: PCB DESIGN

2nd LEVEL INTERCONNECT
7mm X 7mm MODULE.

REV.	DESCRIPTION	DOC./APP.	DATE	REV.	DESCRIPTION	DOC./APP.	DATE
--	INITIAL RELEASE	V.A.W. W.E.A.	11-12-03	--	--	--	--
A	DIM. WAS 4.60	V.A.W. W.E.A.	06-10-04				

This document is proprietary information and may not be reproduced without the written consent of ANADIGICS, INC.

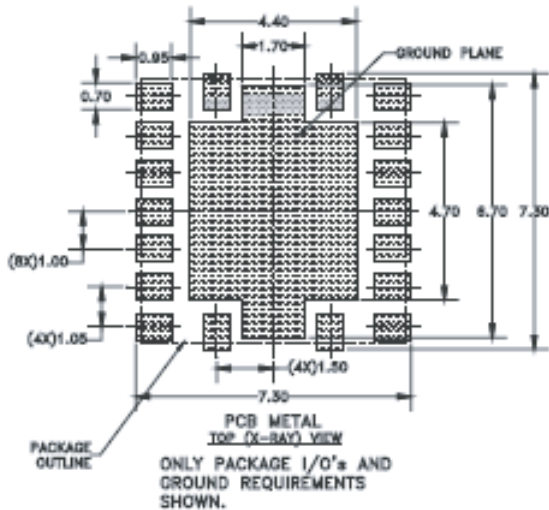

NOTES:

- (1) OUTLINE DRAWING REFERENCE: P8002109
- (2) UNLESS SPECIFIED DIMENSIONS ARE SYMMETRICAL ABOUT CENTER LINES SHOWN.
- (3) DIMENSIONS IN MILLIMETERS.

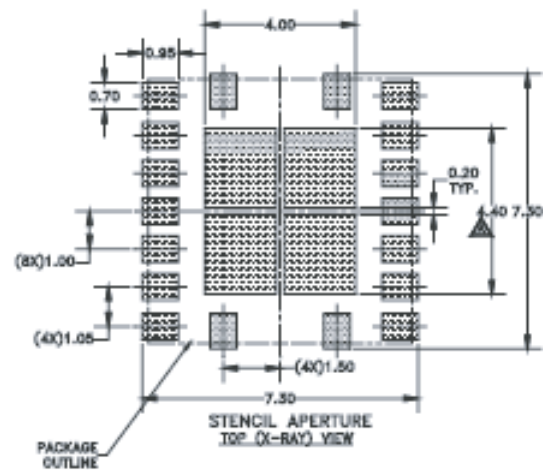
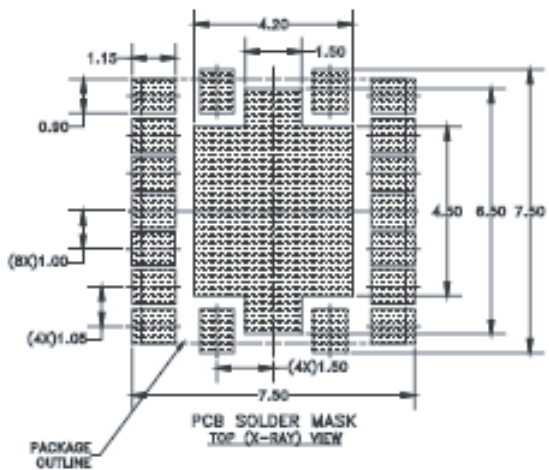

APPENDIX D: 7 mm x 7 mm Module Package Outlines

Soldering Guidelines for Module PCB Mounting

SPECIFICATION: P8002147 (sheet 1 of 3)
 SUBJECT: PCB DESIGN
 2nd LEVEL INTERCONNECT
 11mm X 10.5mm MODULE

REV.	DESCRIPTION	CHKD./APPVD.	DATE	REV.	DESCRIPTION	CHKD./APPVD.	DATE
-	INITIAL RELEASE	M.A.W. W.E.A.	12-09-03	-	-	-	-

This document is proprietary information and may not be reproduced without the written consent of ANADIGICS, INC.

NOTES:

- (1) OUTLINE DRAWING REFERENCE: P8002082
- (2) UNLESS SPECIFIED DIMENSIONS ARE SYMMETRICAL ABOUT CENTER LINES SHOWN.
- (3) DIMENSIONS IN MILLIMETERS.
- (4) PCB ACAD AND GERBER FILES AVAILABLE FOR CLARIFICATION.

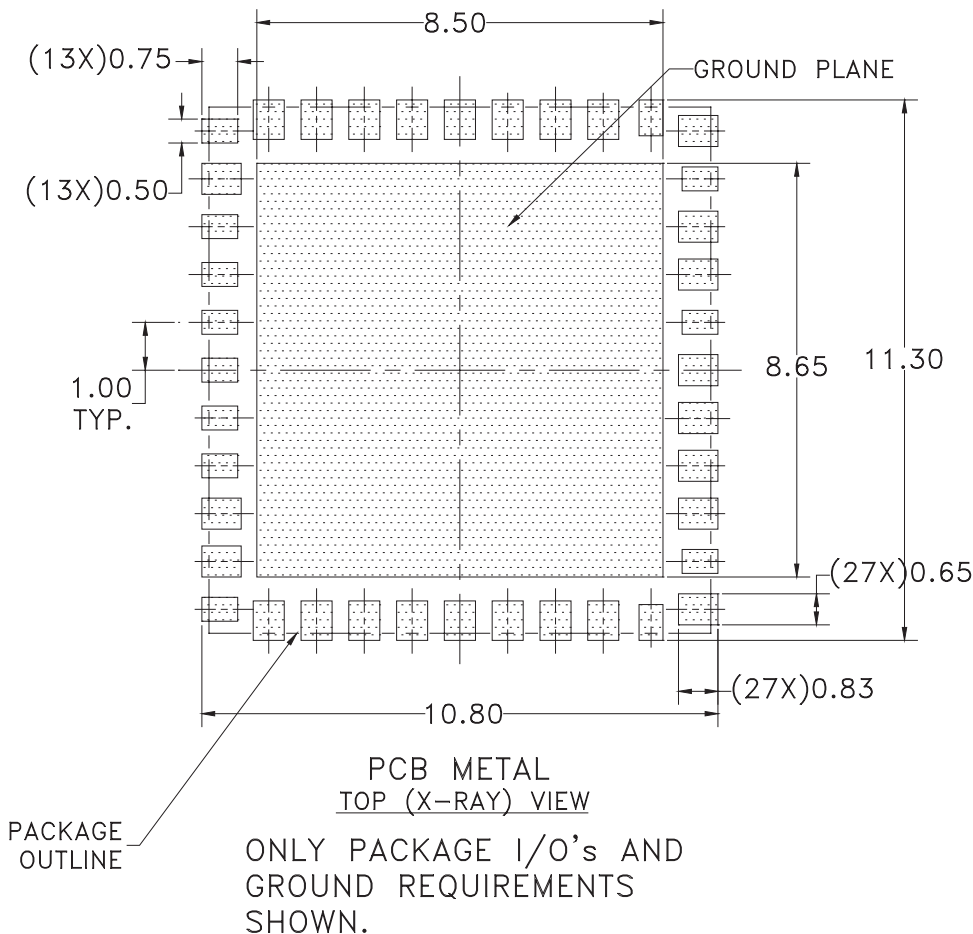

APPENDIX E: 11 mm x 10.5 mm Module PCB Metal Package Outlines

Soldering Guidelines for Module PCB Mounting

SPECIFICATION: P8002147 (sheet 2 of 3)
 SUBJECT: PCB DESIGN
 2nd LEVEL INTERCONNECT
 11mm X 10.5mm MODULE.

REV.	DESCRIPTION	CHKD./APPVD.	DATE	REV.	DESCRIPTION	CHKD./APPVD.	DATE
-	INITIAL RELEASE	M.A.W. W.E.A.	12-09-03	-	-	-	-

This document is proprietary information and may not be reproduced without the written consent of ANADIGICS, INC.

NOTES:

- (1) OUTLINE DRAWING REFERENCE: P8002082
- (2) UNLESS SPECIFIED DIMENSIONS ARE SYMMETRICAL ABOUT CENTER LINES SHOWN.
- (3) DIMENSIONS IN MILLIMETERS.
- (4) PCB ACAD AND GERBER FILES AVAILABLE FOR CLARIFICATION.

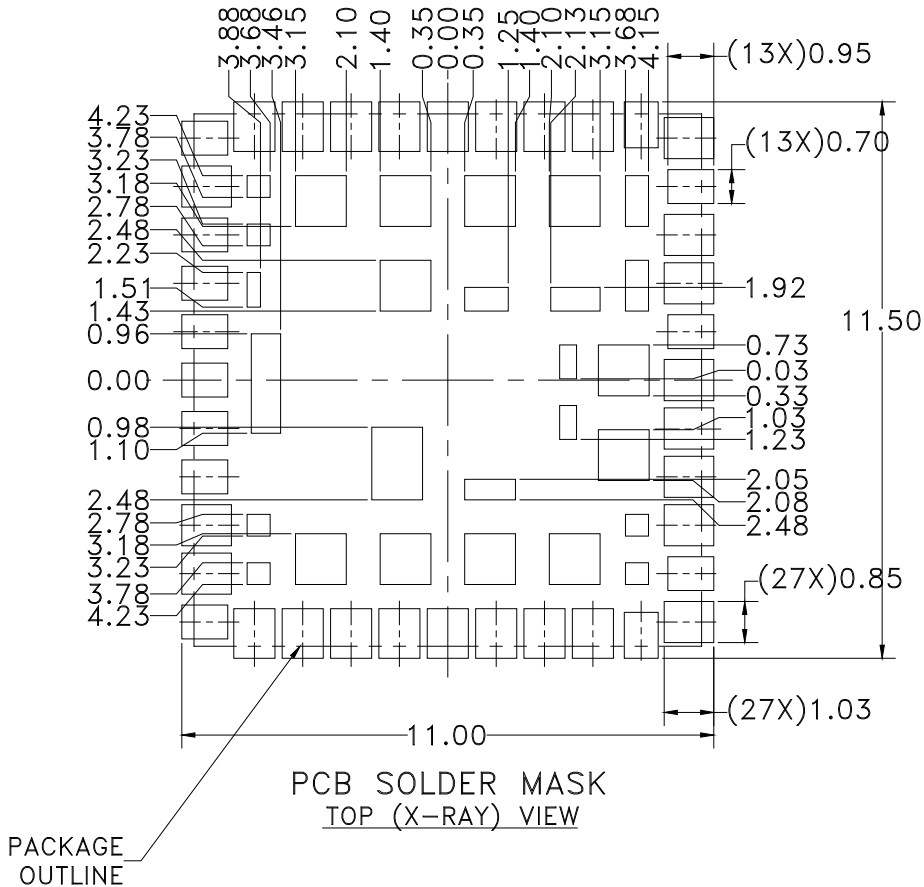

APPENDIX F: 11 mm x 10.5 mm Module PCB Solder Mask Package Outlines

Soldering Guidelines for Module PCB Mounting

SPECIFICATION: P8002170
SUBJECT: PCB DESIGN

2nd LEVEL INTERCONNECT
6mm X 6mm CDMA MODULE.

REV.	DESCRIPTION	CHG./APPV.	DATE	REV.	DESCRIPTION	CHG./APPV.	DATE
-	INITIAL RELEASE	M.A.W. W.F.A.	04-14-04	A	ADDED "CDMA" TO TITLE.	M.A.W. W.F.A.	02-03-06

This document is proprietary information and may not be reproduced without the written consent of ANADIGICS, INC.

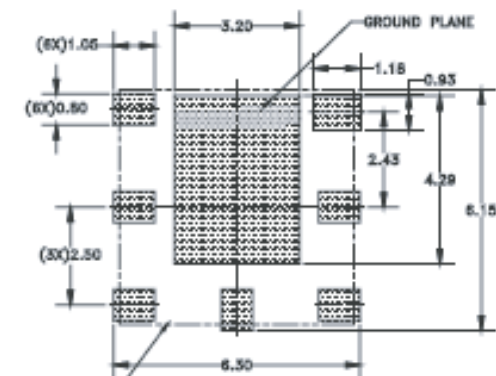

PCB METAL
TOP (X-RAY) VIEW
ONLY PACKAGE I/O's AND
GROUND REQUIREMENTS
SHOWN.

NOTES:

- (1) OUTLINE DRAWING REFERENCE:
98000-034
- (2) UNLESS SPECIFIED DIMENSIONS
ARE SYMMETRICAL ABOUT CENTER
LINES SHOWN.
- (3) DIMENSIONS IN MILLIMETERS.

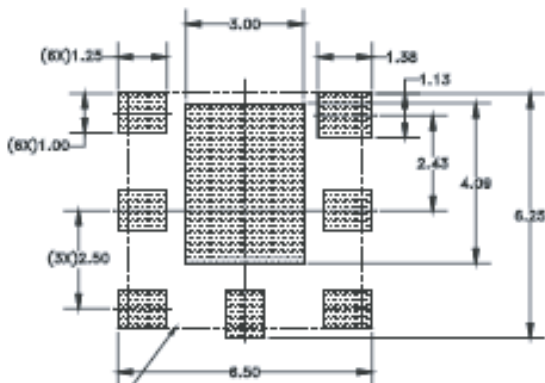

PCB SOLDER MASK
TOP (X-RAY) VIEW

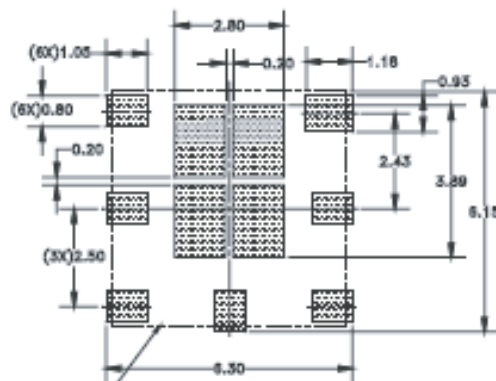

STENCIL APERTURE
TOP (X-RAY) VIEW

APPENDIX H: 6 mm x 6 mm Module Package Outlines

SPECIFICATION: P8002191
 SUBJECT: PCB DESIGN

2nd LEVEL INTERCONNECT
 6mm X 6mm GSM MODULE.

REV.	DESCRIPTION	CHG./APPD.	DATE	REV.	DESCRIPTION	CHG./APPD.	DATE
-	INITIAL RELEASE	WAW/WFA	06-10-04	A	LEAD PITCH WAS 0.88, ADDED "GSM" TO TITLE.	WAW/WFA	02-03-06

This document is proprietary information and may not be reproduced without the written consent of ANADIGICS, INC.

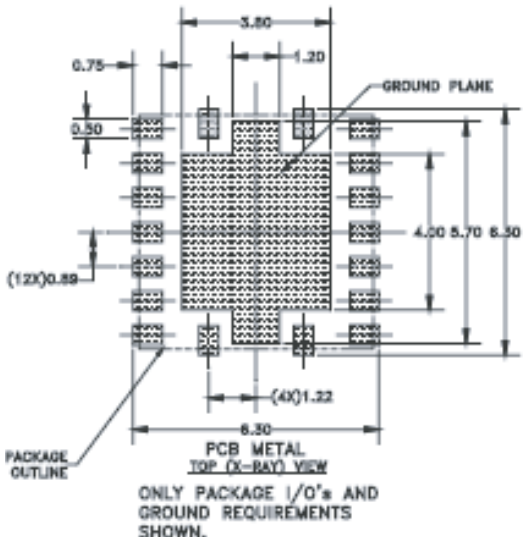

NOTES:

- (1) OUTLINE DRAWING REFERENCE: P8002158
- (2) UNLESS SPECIFIED DIMENSIONS ARE SYMMETRICAL ABOUT CENTER LINES SHOWN.
- (3) DIMENSIONS IN MILLIMETERS.

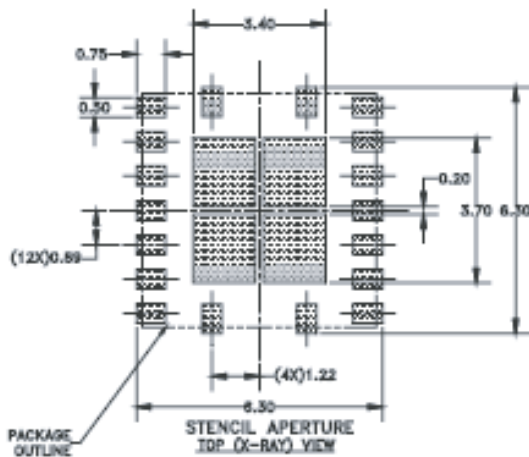
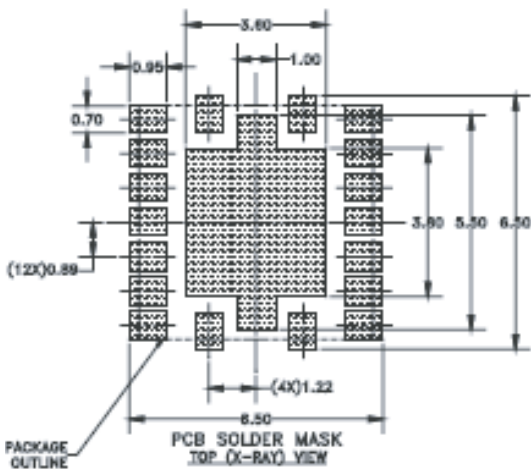

APPENDIX I: 6 mm x 6 mm Module Package Outlines

Soldering Guidelines for Module PCB Mounting

SPECIFICATION: P8002194
SUBJECT: PCB DESIGN

2nd LEVEL INTERCONNECT
4.5mm X 4.5mm MODULE.

REV.	DESCRIPTION	QDD/WPA	DATE	REV.	DESCRIPTION	QDD/WPA	DATE
-	INITIAL RELEASE	W.A.V. W.E.A.	06-18-04	A	CORRECTED OUTLINE DRAWING NUMBER-WAS P8002193.	W.E.A.	03-25-05
B	PCB METAL & STENCIL PAD WWS 0.40 X 0.85. SOLDER MASK PAD WAS 0.80 X 0.85.	W.A.V. W.E.A.	04-20-06				

This document is proprietary information and may not be reproduced without the written consent of ANADIGICS, INC.

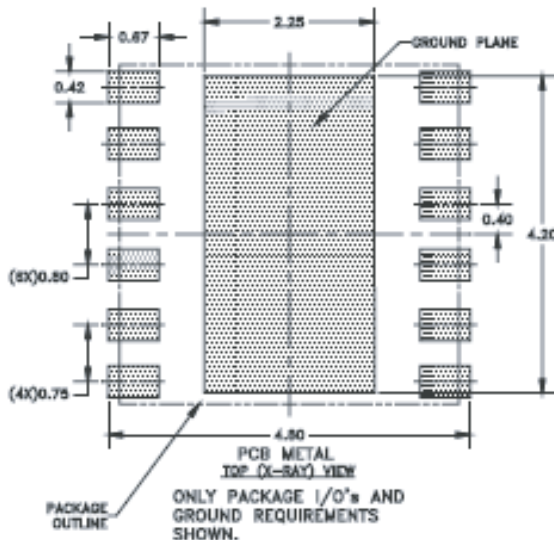

- NOTES:**
- (1) OUTLINE DRAWING REFERENCE:
* P8002186
 - (2) UNLESS SPECIFIED DIMENSIONS ARE SYMMETRICAL ABOUT CENTER LINES SHOWN.
 - (3) DIMENSIONS IN MILLIMETERS.

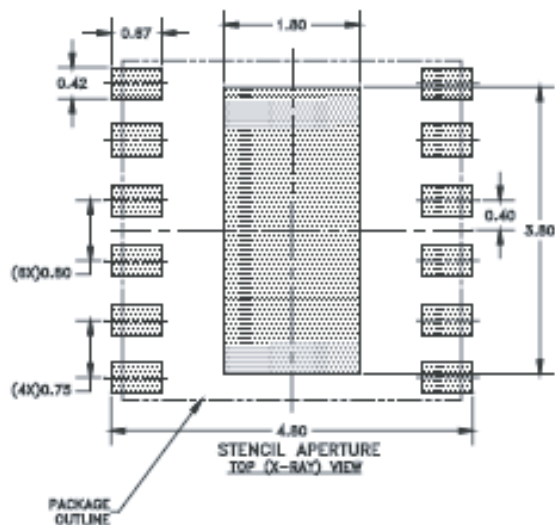
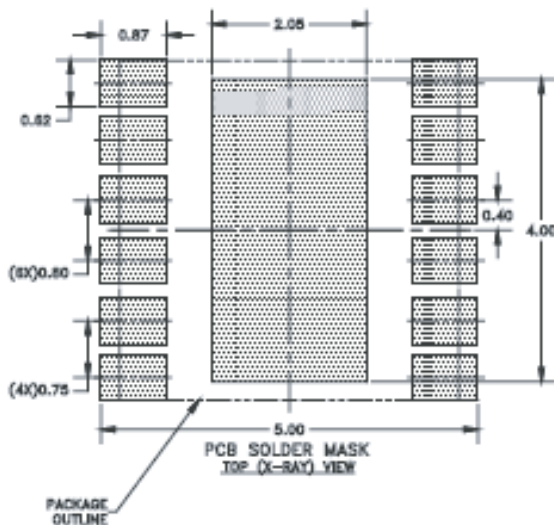

APPENDIX J: 4.5 mm x 4.5 mm Module Package Outlines

SPECIFICATION: P8002253
 SUBJECT: PCB DESIGN

2nd LEVEL INTERCONNECT
 3mm X 3mm MODULE.
 (9 TERMINAL)

REV.	DESCRIPTION	QCD/APP.	DATE	REV.	DESCRIPTION	QCD/APP.	DATE
-	INITIAL RELEASE	M.W. W.E.A.	03-17-08	-	-	-	-

This document is proprietary information and may not be reproduced without the written consent of ANADIGICS, INC.

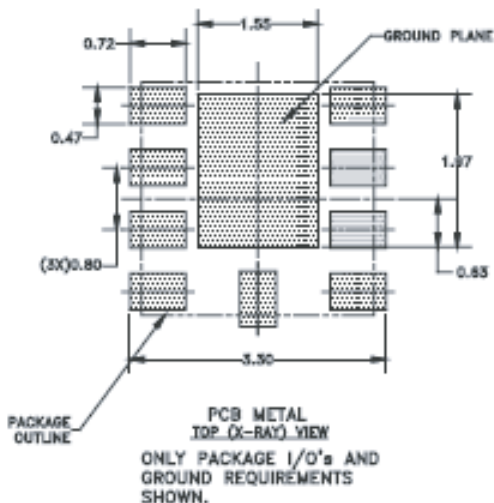

NOTES:

- (1) OUTLINE DRAWING REFERENCE:
 * 98000-049
 -
- (2) UNLESS SPECIFIED DIMENSIONS ARE SYMMETRICAL ABOUT CENTER LINES SHOWN.
- (3) DIMENSIONS IN MILLIMETERS.

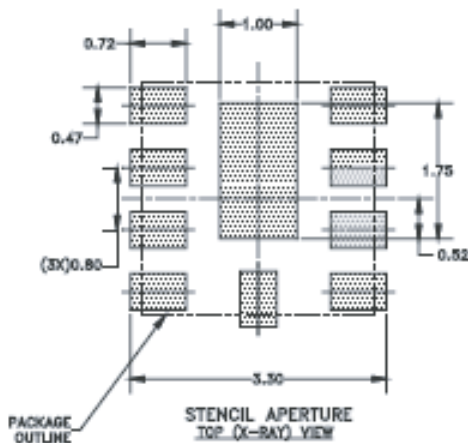
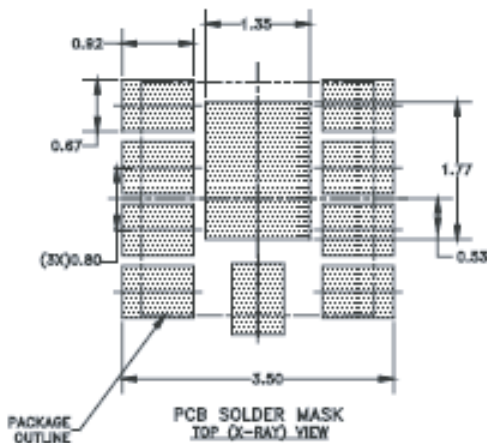

APPENDIX K: 4.5 mm x 4.5 mm Module Package Outlines

Soldering Guidelines for Module PCB Mounting

SPECIFICATION: P8002254
 SUBJECT: PCB DESIGN

2nd LEVEL INTERCONNECT
 3mm X 3mm MODULE
 (9 TERMINAL - REVERSED PATTERN)

REV.	DESCRIPTION	QDC/WPL	DATE	REV.	DESCRIPTION	QDC/WPL	DATE
-	INITIAL RELEASE	N.A.W. W.F.A.	03-17-05	-	-	-	-

This document is proprietary information and may not be reproduced without the written consent of ANADIGICS, INC.

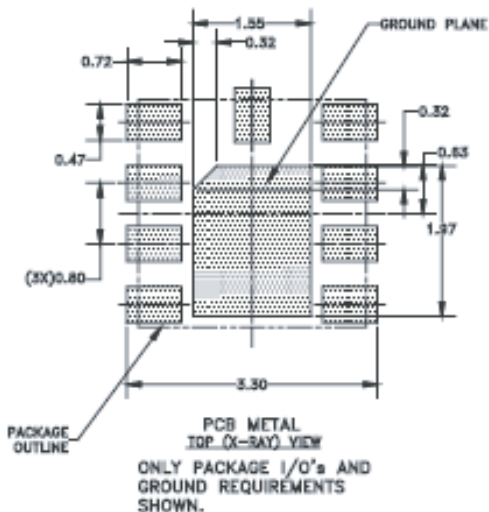

NOTES:

- (1) OUTLINE DRAWING REFERENCE:
 * P8002223
 -
- (2) UNLESS SPECIFIED DIMENSIONS ARE SYMMETRICAL ABOUT CENTER LINES SHOWN.
- (3) DIMENSIONS IN MILLIMETERS.

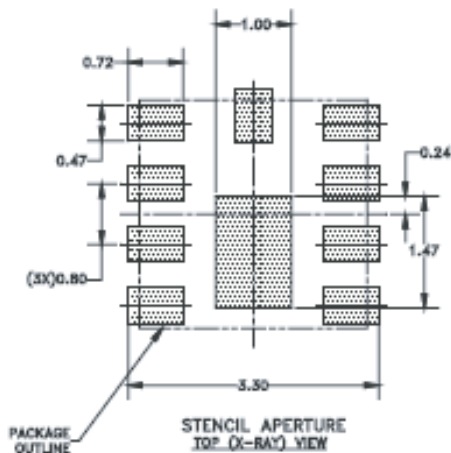
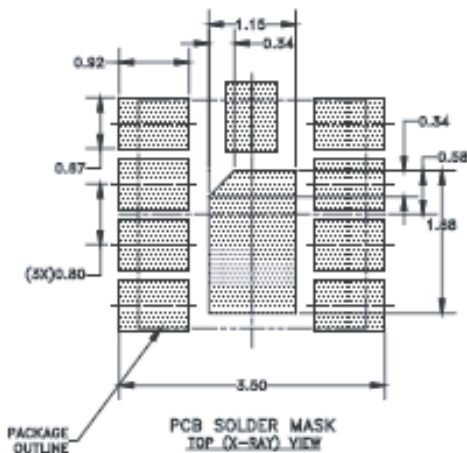

APPENDIX L: 3 mm x 3 mm (9 Terminal - Reversed Pattern) Module Package Outlines

SPECIFICATION: P8002272
SUBJECT: PCB DESIGN

2nd LEVEL INTERCONNECT
3mm X 5mm MODULE.
(MIRRORED)

REV.	DESCRIPTION	DOE, WVL	DATE	REV.	DESCRIPTION	DOE, WVL	DATE
-	INITIAL RELEASE	M.A.V. W.E.A.	06-09-06	-	-	-	-

This document is proprietary information and may not be reproduced without the written consent of ANADIGICS, INC.

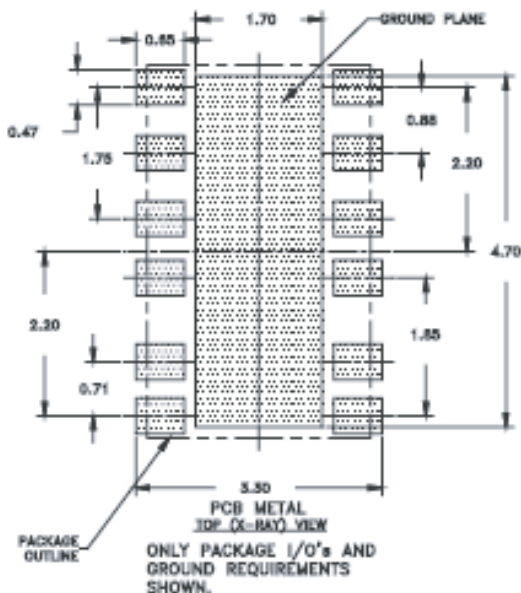

NOTES:

- (1) OUTLINE DRAWING REFERENCE: P8002267
- (2) UNLESS SPECIFIED DIMENSIONS ARE SYMMETRICAL ABOUT CENTER LINES SHOWN.
- (3) DIMENSIONS IN MILLIMETERS.

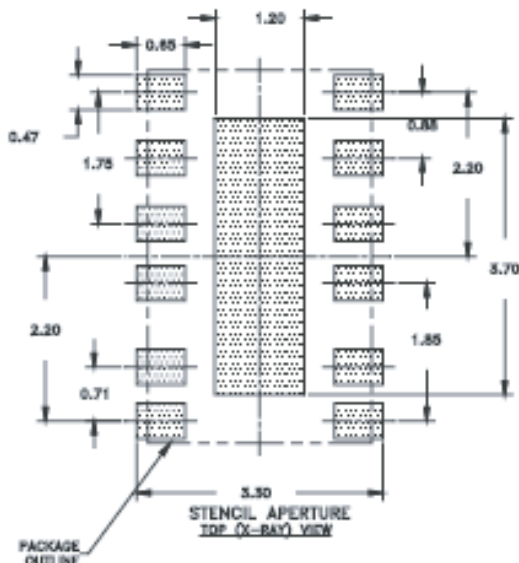
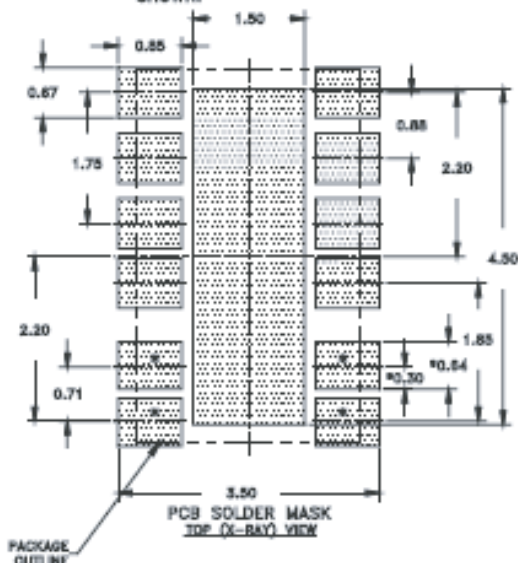

APPENDIX M: 3 mm x 5 mm Mirrored Module Package Outlines

Soldering Guidelines for Module PCB Mounting

SPECIFICATION: P8002273
 SUBJECT: PCB DESIGN

2nd LEVEL INTERCONNECT
 3mm X 5mm MODULE.

REV.	DESCRIPTION	CHG./APP.	DATE	REV.	DESCRIPTION	CHG./APP.	DATE
-	INITIAL RELEASE	M.A.W. W.E.A.	08-10-05	-	-	-	-

This document is proprietary information and may not be reproduced without the written consent of ANADIGICS, INC.

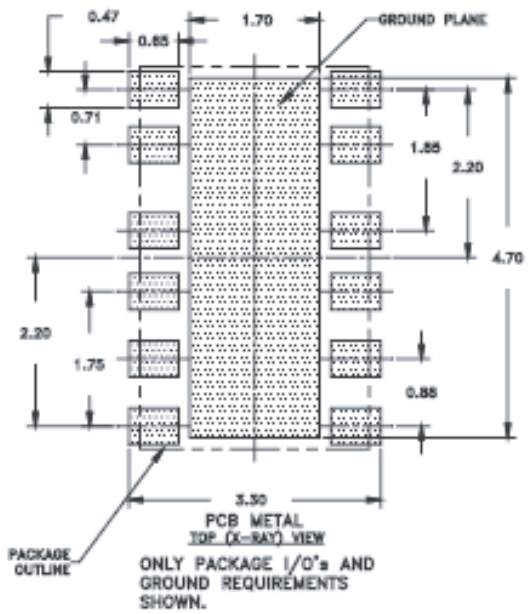

- NOTES:
- (1) OUTLINE DRAWING REFERENCE: P8002246
 - (2) UNLESS SPECIFIED DIMENSIONS ARE SYMMETRICAL ABOUT CENTER LINES SHOWN.
 - (3) DIMENSIONS IN MILLIMETERS.

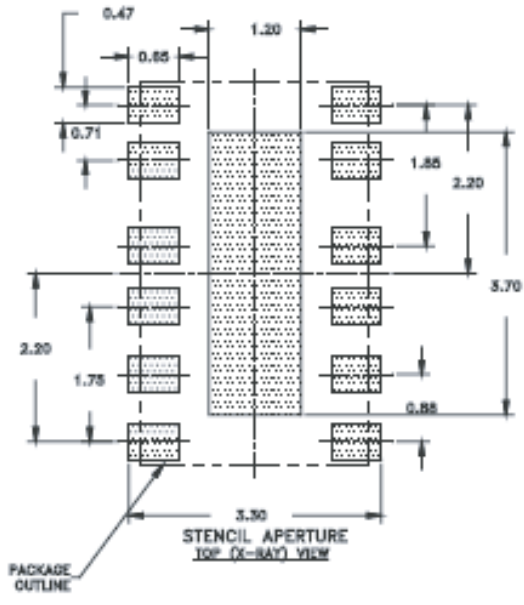
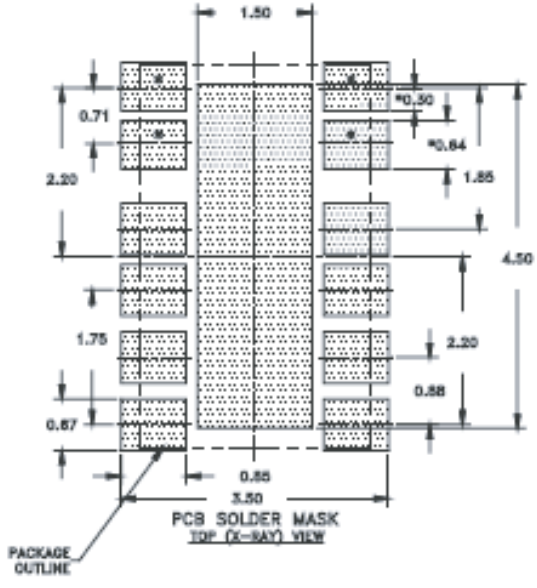

APPENDIX N: 3 mm x 5 mm Module Package Outlines

Soldering Guidelines for Module PCB Mounting

SPECIFICATION: P8002367
 SUBJECT: PCB DESIGN
 2nd LEVEL INTERCONNECT
 3mm X 3mm MODULE
 (10 PIN) (CASE STYLE: M27)

REV.	DESCRIPTION	CHKD./APPVD.	DATE	REV.	DESCRIPTION	CHKD./APPVD.	DATE
-	INITIAL RELEASE	K.S. M.A.W.	7-20-06	B	OUTLINE DRAWING WAS P8002310	W.E.A. M.A.W.	11-29-07
A	PCB METAL "Y" DIM. CORRECTED TO 0.42. ADDED PITCH DIM.	W.E.A. M.A.W.	07-25-06	C	ADDED CASE STYLE	U.B.	7-19-10

This document is proprietary information and may not be reproduced without the written consent of ANADIGICS, INC.

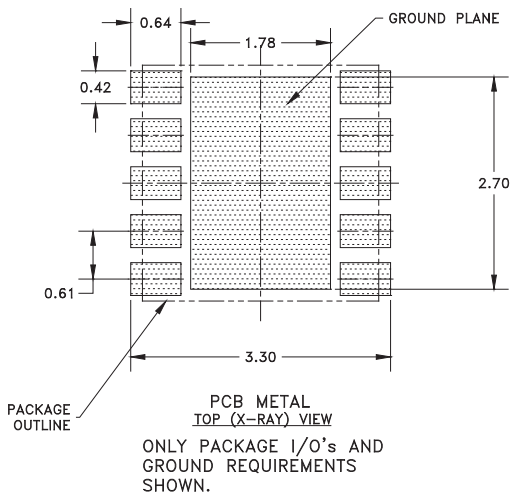

NOTES:

- (1) OUTLINE DRAWING REFERENCE: 98000-073
- (2) UNLESS SPECIFIED DIMENSIONS ARE SYMMETRICAL ABOUT CENTER LINES SHOWN.
- (3) DIMENSIONS IN MILLIMETERS.
- (4) PCB SOLDERMASK KEPT OPEN FOR I/O's DUE TO SMALLER I/O PITCH.

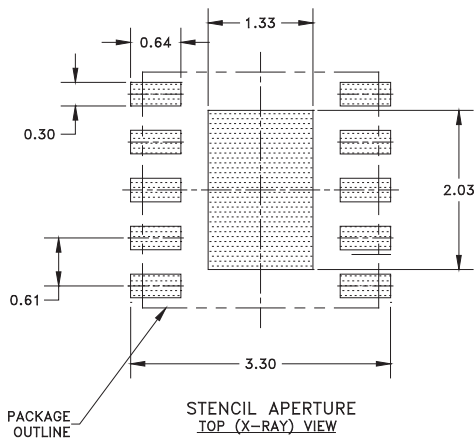
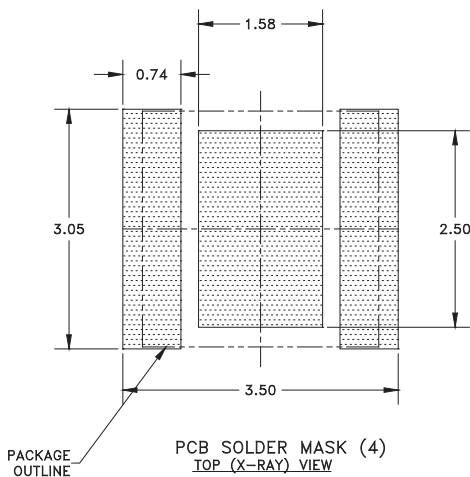

APPENDIX O: 3 mm x 3 mm (10 Pin) Module Package Outlines

Soldering Guidelines for Module PCB Mounting

SPECIFICATION: ANE_P8002478_E
 SUBJECT: PCB DESIGN (Laminate Based)
 2nd LEVEL INTERCONNECT
 3mmX3mm [Case Style M45]
 (10 TERMINAL)

REV.	DESCRIPTION	CHKD./APPVD.	DATE	REV.	DESCRIPTION	CHKD./APPVD.	DATE
-	INITIAL RELEASE	K.S.	04-12-09	-	-	-	-
E	Case Style typeM45 added	K.S.	04-14-09				

This document is proprietary information and may not be reproduced without the written consent of ANADIGICS, INC.

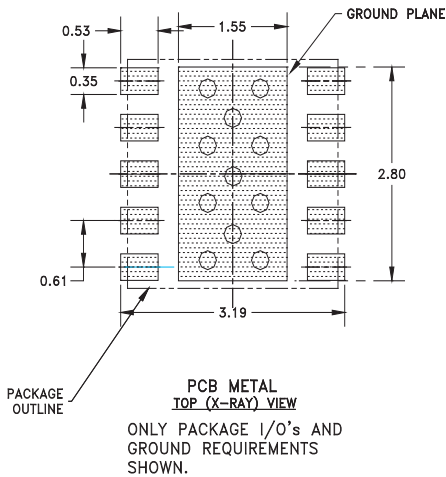

NOTES:

- (1) OUTLINE DRAWING REFERENCE: P8002478_E
- (2) UNLESS SPECIFIED DIMENSIONS ARE SYMMETRICAL ABOUT CENTER LINES SHOWN.
- (3) DIMENSIONS IN MILLIMETERS.
- (4) VIAS SHOWN IN PCB METAL VIEW ARE FOR REFERENCE ONLY. NUMBER & SIZE OF THERMAL VIAS REQUIRED DEPENDENT ON HEAT DISSIPATION REQUIREMENT AND THE PCB PROCESS CAPABILITY.
- (5) RECOMMENDED STENCIL THICKNESS: APPROX. 0.150mm (6 Mils)

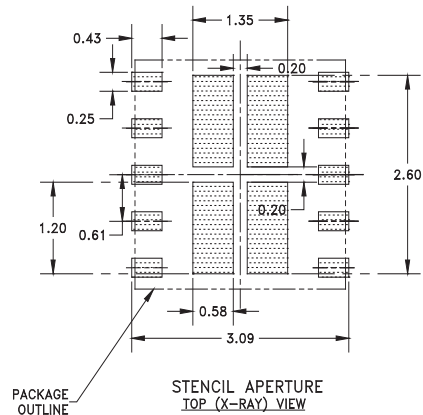
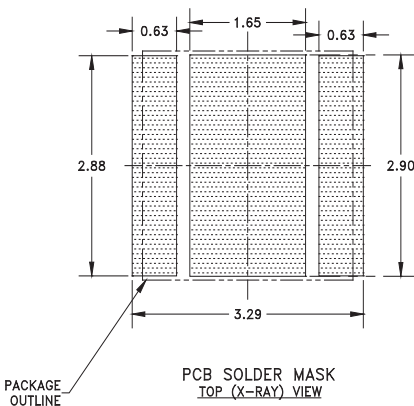

APPENDIX P: 3 mm x 3 mm (10 Terminal) Module Package Outlines

SPECIFICATION: P8002387
 SUBJECT: PCB DESIGN

2nd LEVEL INTERCONNECT
 3mm X 5mm MODULE
 (14 TERMINAL)

REV.	DESCRIPTION	DRG./WFE	DATE	REV.	DESCRIPTION	DRG./WFE	DATE
-	INITIAL RELEASE	K.S. M.A.W.	9-13-6	-	-	-	-

This document is proprietary information and may not be reproduced without the written consent of ANADIGICS, INC.

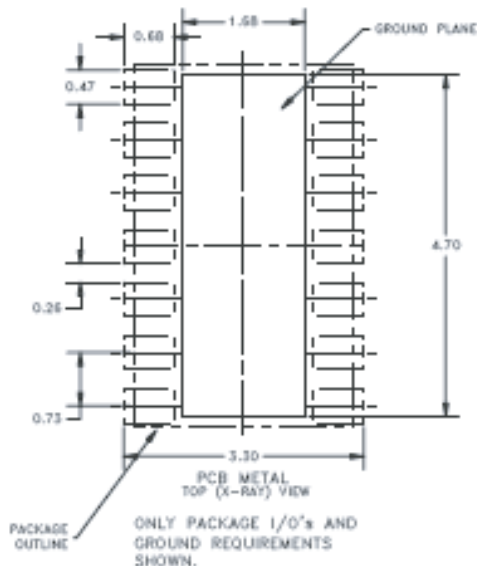

- NOTES:
- (1) OUTLINE DRAWING REFERENCE: P8002311
 - (2) UNLESS SPECIFIED DIMENSIONS ARE SYMMETRICAL ABOUT CENTER LINES SHOWN.
 - (3) DIMENSIONS IN MILLIMETERS.

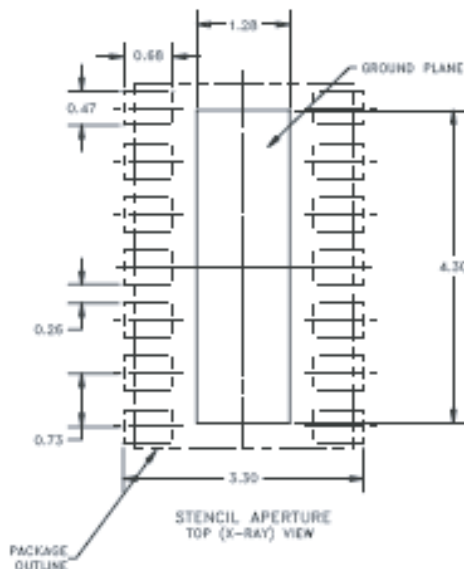
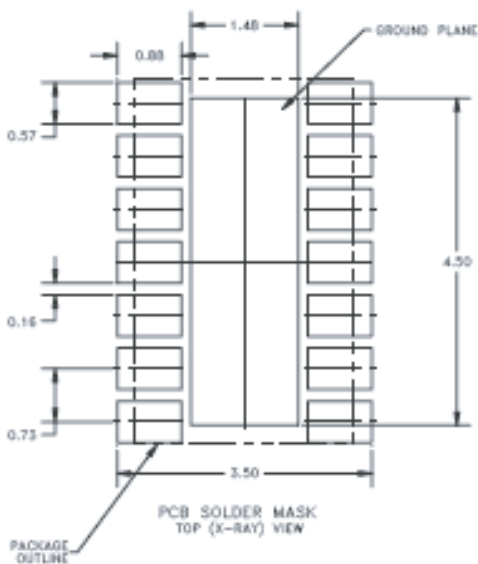

APPENDIX Q: 3 mm x 5 mm (14 Terminal) Module Package Outlines

Soldering Guidelines for Module PCB Mounting

SPECIFICATION: PB002392
 SUBJECT: PCB DESIGN

2nd LEVEL INTERCONNECT
 5mm X 5mm MODULE
 (16 TERMINAL)

REV.	DESCRIPTION	DRG./WPR.	DATE	REV.	DESCRIPTION	DRG./WPR.	DATE
--	INITIAL RELEASE	K.S. M.A.W.	10/6/8	1	--	--	--
	Redesign Stencil Ground Plane	K.S. M.A.W.	10/13/8				

This document is proprietary information and may not be reproduced without the written consent of ANADIGICS, INC.

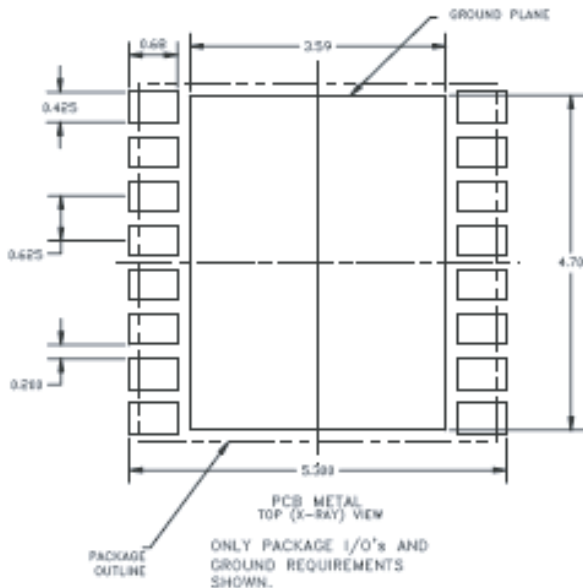

- NOTES:
- (1) OUTLINE DRAWING REFERENCE: PB002391
 - (2) UNLESS SPECIFIED DIMENSIONS ARE SYMMETRICAL ABOUT CENTER LINES SHOWN.
 - (3) DIMENSIONS IN MILLIMETERS.
 - (4) PCB SOLDERMASK KEPT OPEN FOR I/O's DUE TO SMALLER I/O PITCH.

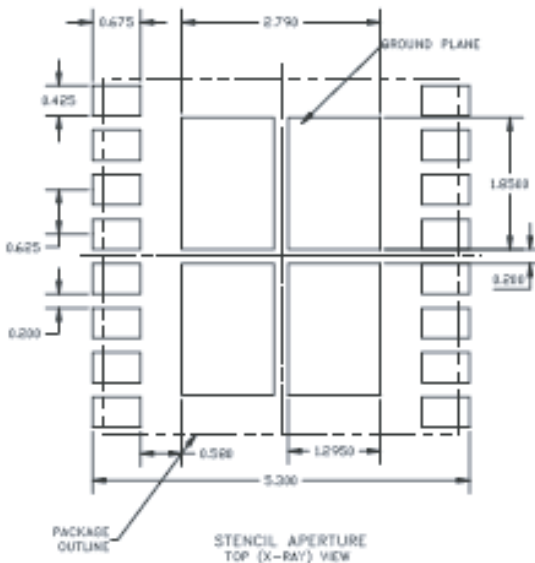
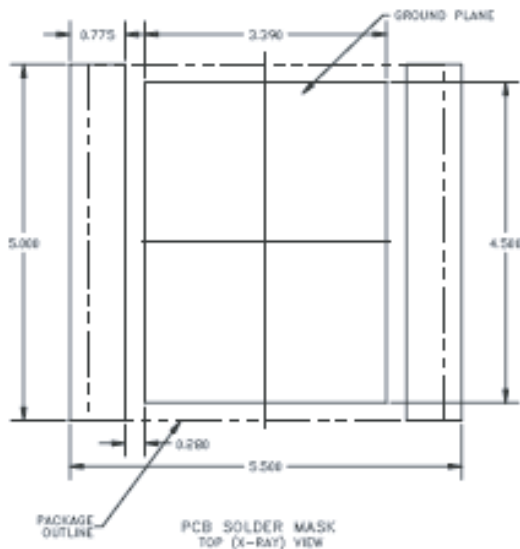

APPENDIX R: 5 mm x 5 mm (16 Terminal) Module Package Outlines

SPECIFICATION: P8002355 2nd LEVEL INTERCONNECT
 6.8mm X 8mm
 (28 PIN)

REV.	DESCRIPTION	ECN#/APP	DATE	REV.	DESCRIPTION	ECN#/APP	DATE
A	INITIAL RELEASE	K.S.	01-18-07	--	--	--	--

This document is proprietary information and may not be reproduced without the written consent of ANADIGICS, INC.

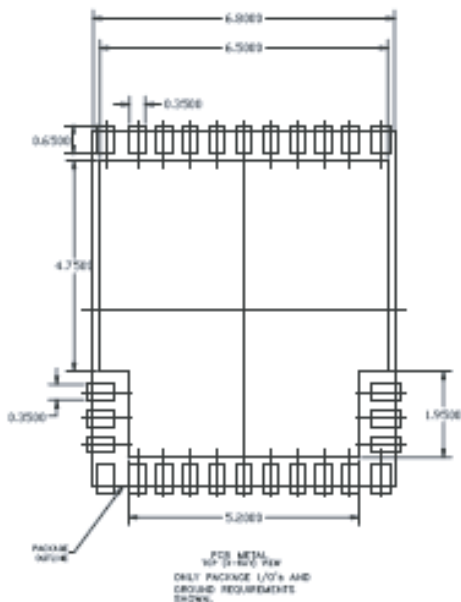

- NOTES:
- (1) OUTLINE DRAWING REFERENCE: P8002355
 - (2) UNLESS SPECIFIED DIMENSIONS ARE SYMMETRICAL ABOUT CENTER LINES SHOWN.
 - (3) DIMENSIONS IN MILLIMETERS.

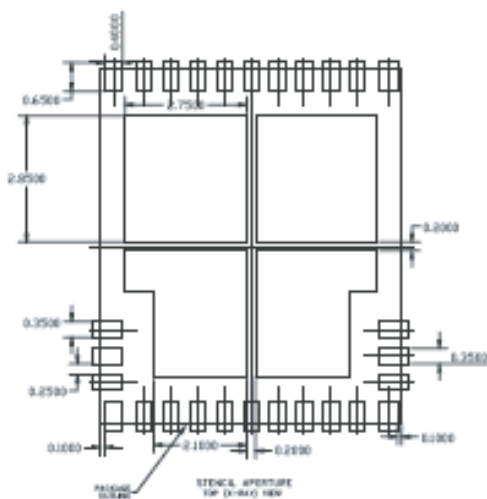
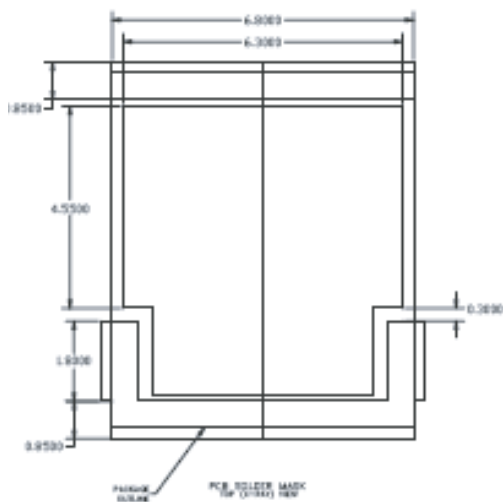

APPENDIX S: 6.8 mm x 8 mm (28 Pin) Module Package Outlines

Soldering Guidelines for Module PCB Mounting

SPECIFICATION: ANP8002482_B
 SUBJECT: PCB METAL & SOLDERMASK
 5mm x 7mm (LAMINATE BASED)
 22 LEAD CASE STYLE M48

REV.	DESCRIPTION	CHKD./APPVD.	DATE	REV.	DESCRIPTION	CHKD./APPVD.	DATE
A	INITIAL RELEASE	MD/KS	8/31/09	-	-	-	-
B	Change ground pad size	JW	7/16/10				

This document is proprietary information and may not be reproduced without the written consent of ANADIGICS, INC.

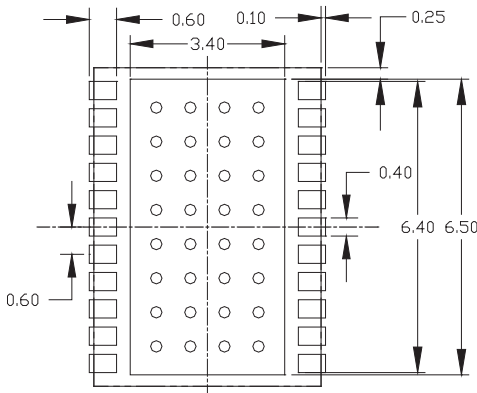

PCB METAL
TOP (X-RAY) VIEW

NOTES:

- (1) OUTLINE DRAWING REFERENCE:
P8002482
- (2) UNLESS SPECIFIED DIMENSIONS ARE SYMMETRICAL ABOUT CENTER LINES SHOWN.
- (3) DIMENSIONS IN MILLIMETERS.
- (4) VIAS SHOWN IN PCB METAL VIEW ARE FOR REFERENCE ONLY. NUMBER & SIZE OF THERMAL VIAS REQUIRED DEPENDENT ON HEAT DISSIPATION REQUIREMENT AND THE PCB PROCESS CAPABILITY.
- (5) RECOMMENDED STENCIL THICKNESS: APPROX. 0.125mm (5 Mils)

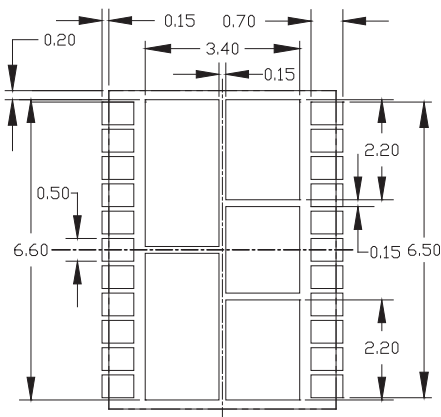

PCB SOLDER MASK
TOP (X-RAY) VIEW

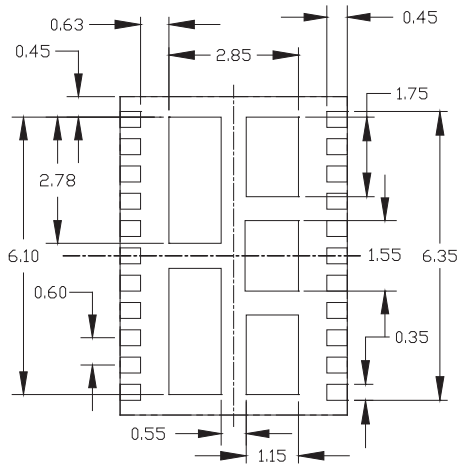

STENCIL APERTURE
TOP (X-RAY) VIEW

APPENDIX T: 5 mm x 7 mm Module Package Outlines



ANADIGICS, Inc.

141 Mount Bethel Road

Warren, New Jersey 07059, U.S.A.

Tel: +1 (908) 668-5000

Fax: +1 (908) 668-5132

URL: <http://www.anadigics.com>

IMPORTANT NOTICE

ANADIGICS, Inc. reserves the right to make changes to its products or to discontinue any product at any time without notice. The product specifications contained in Advanced Product Information sheets and Preliminary Data Sheets are subject to change prior to a product's formal introduction. Information in Data Sheets have been carefully checked and are assumed to be reliable; however, ANADIGICS assumes no responsibilities for inaccuracies. ANADIGICS strongly urges customers to verify that the information they are using is current before placing orders.

WARNING

ANADIGICS products are not intended for use in life support appliances, devices or systems. Use of an ANADIGICS product in any such application without written consent is prohibited.