

RELEVANT PRODUCTS

- AWT6278
- AWT6279
- AWT6282

GENERAL DESCRIPTION

The ANADIGICS 4 mm x 4 mm hetero-junction bipolar transistor (HBT) power amplifier modules designed UMTS High Band, and operates from a single lithium-ion (Li-ion) battery. The amplifier input and output are matched to provide optimum performance in a

50 Ω system; only minimal external components are required for proper RF bypassing.

Table 1: Module Pin Description

PIN	NAME	DESCRIPTION	NOTES
1	V _{BATT}	Battery Voltage	+3.2 to +4.2 V
2	RF _{IN}	RF Input	Use 50 Ω transmission line
3	V _{MODE1}	Mode Control Voltage 1	
4	V _{MODE2}	Mode Control Voltage	+2.15 to +3.1 V for Low Bias Mode 0 to +0.5 V for High Bias Mode
5	V _{ENABLE}	PA Enable Voltage	+2.15 to +3.1 V for PA "on" 0 to +0.5 V for PA "shut down"
8	RF _{OUT}	RF Output	Use 50 Ω transmission line
10	V _{CC}	Supply Voltage	+3.2 to +4.2 V
6, 7, 9	GND	Ground	

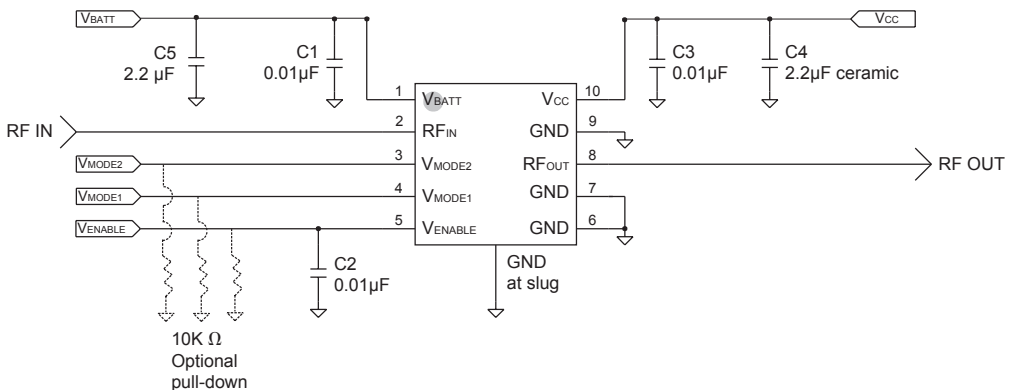

Figure 1: Application Schematic

EVALUATION BOARD

The evaluation board, shown in Figure 2, was designed on ROGERS (R04033) material with 8 mils thickness.

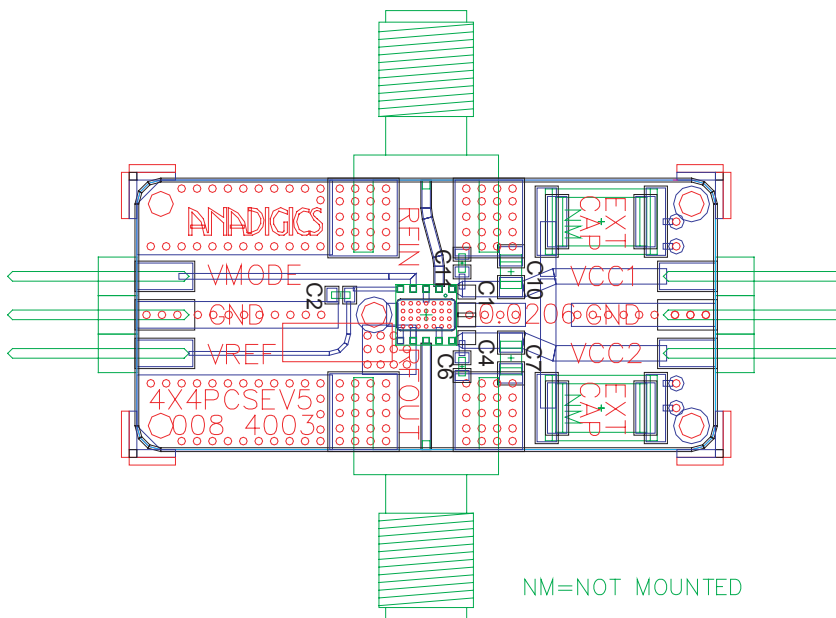

Figure 2: Evaluation Board Layout

Notes:

1. Copper trace width is 20.6 mils.
2. Relative dielectric constant is 3.38 at 1 GHz.
3. Dielectric thickness is 8.0 mils.

Table 2: Evaluation Board Parts List

DESCRIPTION	VALUE	SIZE	MANUFACTURER	MANUFACTURER'S P/N (Qty.)
C1, C2, C3	0.01 μ F	0603	Panasonic	ECJ-2YB1E103K (3)
C4, C5 ⁽¹⁾	2.2 μ F	0805	Panasonic	ECJ-2YB0J225K (2)
PC Board	-	-	-	4x4PCSEVB (1)
Sma Conn.	-	-	Johnson Comp.	142-0701-851 (2)
Conn. Hdr.	-	-	AMP	4-103321-0
Alum. Block	-	-	-	Edgemountbase1 (1)

Notes:

- (1) Capacitors C4 and C5 must be ceramic type and 2.2 μ F value only.
2. If any DC signal is present at the input of this amplifier – the blocking capacitor should be used, placed in series to RF input trace. It is recommended to use a ceramic (0603 10 pF) capacitor.
3. Output Power at antenna port of the phone board should not exceed the power level specified on the data sheet (PA Max. output power - Front-end loss). All VSWR value at PA output port toward the antenna port should be lower than 8:1 under 28.5 dBm P_{OUT} condition, and lower than 5:1 in the absolute maximum RF output power (+31 dBm) condition.

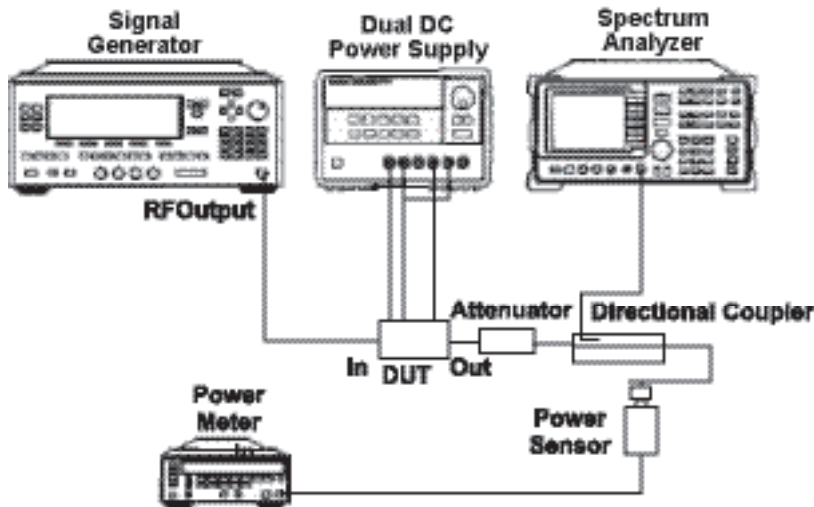

Test Setup Notes:

1. Figure 3 shows minimum equipment required for proper power amplifier operation.
2. Depending upon the power sensor, 10 to 20 dB attenuator is sufficient to prevent overloading of the power meter or the spectrum analyzer.

Test Equipment

The following test equipment is recommended for testing of WCDMA IMT/PCS evaluation boards.

- One RF WCDMA⁽¹⁾ signal generator capable of delivering at least +5 dBm of output power at the operating frequency band (Agilent E4432B).
- One RF power meter capable of measuring up to +30 dBm at the operating frequency band (Agilent E4419B).
- One RF power sensor capable of measuring RF power in the range from -50 dBm to +30 dBm at the operating frequency band (Agilent E9301H).
- One RF spectrum analyzer capable of measuring ACP in operating frequency band and covering up to the 3-rd harmonic of the highest frequency in band (Rohde & Schwarz FSP).
- One DC power supply capable of delivering 1.5 A at +4 V and 500 mA at +3 V (Agilent 6624A)
- One SMA 10 dB attenuator capable of handling 2 watts.

Notes:

(1) WCDMA: 3GPP 32-03-00, uplink, DPCCH + DPDCH and HSDPA

Test Setup

1. Set DC power supply to +3.4 V (for V_{BATT} and V_{CC}), to +2.85 V (for V_{EN}), and to 0 V (for $V_{MODE1,2}$).
2. Set power meter measured frequency to 1950 MHz for IMT band (1750 MHz for 1700 band) and its calibration factor to correspond to the set frequency.
3. Set power meter offset value equal to the total loss of the attenuator, directional coupler, and connecting cables.
4. Set spectrum analyzer center frequency to 1950 MHz for IMT band (1750 MHz for 1700 band) and enable WCDMA(3GPP) measuring personality.
5. Select and enable WCDMA digital signal on the signal generator.
6. Set signal generator frequency to 1950 MHz for IMT band (1750 MHz for 1700 band) and output power to -10 dBm.
7. Ensure DC power supply is disabled and RF output of a signal generator is OFF.
8. Connect evaluation board to the test setup as shown.
9. Turn on DC power supply and measure the idle current.
10. Switch RF output of a signal generator to ON.
11. Increase amplitude of a signal generator to the desired output power level (according to the corre-

sponding data sheet).

12. Measure and record ACP, Gain (as a difference between Input and Output power levels) and total current consumption.

Test sequence (Recommended PA turn-on and turn-off sequences):

Turn-on sequence:

1. Connect DUT according to the setup shown on Figure 3. **Do not** turn on DC power supply before connecting DUT to RF input and output cables (make sure that RF output of a signal generator is OFF before connecting RF cables to DUT).
2. Turn on V_{CC} first and then turn on V_{REF} and V_{MODE} .
3. Turn RF output of a signal generator ON and make measurements.

Turn-off sequence:

1. Turn RF output of a signal generator OFF. **Do not** disconnect DUT from RF input and output cables before turning off DC power supply.
2. Turn off V_{REF} and V_{MODE} , and then V_{CC} .
3. Disconnect DUT from the test setup.

Layout Considerations

A sufficient number of holes (QTY 12 - 0.2 mm diameter plated through hole) should be placed under the module in order to channel the heat properly. In addition, contact should be made between the PA slug located under the amplifier and the board. For hand assembly of the board, place sufficient bonding paste so that contact is made between the PA and ground. For large volume assembly, please refer to the solder profile recommendations application note. For RF_{IN} and RF_{OUT} , provide 50 Ω transmission lines.

Application Information

To ensure proper performance, refer to all related Application Notes on the ANADIGICS web site: <http://www.anadigics.com>

Shutdown Mode

The power amplifier may be placed in a shutdown mode by applying logic low levels (see Operating Ranges table) to the V_{ENABLE} , V_{MODE1} and V_{MODE2} voltages.

Bias Modes

The power amplifier may be placed in either a Low Bias mode or a High Bias mode by applying the appropriate logic level (see Operating Ranges table) to the V_{MODE} voltages. The Bias Control table lists the recommended modes of operation for various applications.

Three operating modes are recommended to optimize current consumption. High Bias/High Power operating mode is for P_{OUT} levels > 16 dBm. At ~16dBm - 7 dBm, the PA should be "Mode Switched" to Medium Power Mode. For P_{OUT} levels < ~8 dBm, the PA can be switched to Low Power Mode for even lower quiescent current consumption.

Output Power/VSWR Mandatory

Output Power at antenna port of the phone board should not exceed the power level specified on the data sheet (PA Max. output power - Front-end loss). All VSWR value at PA output port toward the antenna port should be lower than 8:1 under 28.5 dBm P_{OUT} condition, and lower than 5:1 in the absolute maximum RF output power (+31 dBm) condition.

Table 5: Bias Control

APPLICATION	P _{OUT} LEVELS	BIAS MODE	V _{ENABLE}	V _{MODE1}	V _{MODE2}	V _{CC}	V _{BATT}
WCDMA - low power (Low Bias Mode)	≤ +8 dBm	Low	+2.4 V	+2.4 V	+2.4 V	3.2 - 4.2 V	≥ 3.2 V
WCDMA - med power (Medium Bias Mode)	7 P _{OUT} ≤ +16 dBm	Low	+2.4 V	+2.4 V	0 V	3.2 - 4.2 V	≥ 3.2 V
WCDMA - high power (High Bias Mode)	> +16 dBm	High	+2.4 V	0 V	0 V	3.2 - 4.2 V	≥ 3.2 V
Optional lower V _{CC} in low power mode	≤ +7 dBm	Low	+2.4 V	+2.4 V	2.4 V	1.5 V	≥ 3.2 V
Shutdown	-	Shutdown	0 V	0 V	0 V	3.2 - 4.2 V	≥ 3.2 V

NOTES

NOTES



ANADIGICS, Inc.

141 Mount Bethel Road

Warren, New Jersey 07059, U.S.A.

Tel: +1 (908) 668-5000

Fax: +1 (908) 668-5132

URL: <http://www.anadigics.com>

E-mail: Mktg@anadigics.com

IMPORTANT NOTICE

ANADIGICS, Inc. reserves the right to make changes to its products or to discontinue any product at any time without notice. The product specifications contained in Advanced Product Information sheets and Preliminary Data Sheets are subject to change prior to a product's formal introduction. Information in Data Sheets have been carefully checked and are assumed to be reliable; however, ANADIGICS assumes no responsibilities for inaccuracies. ANADIGICS strongly urges customers to verify that the information they are using is current before placing orders.

WARNING

ANADIGICS products are not intended for use in life support appliances, devices or systems. Use of an ANADIGICS product in any such application without written consent is prohibited.